

ELITE.M

Class







CONTENTS

FINE MONO

SWISS LACE

FRENCH LACE

WELDED LACE

SKIN

COMBINATIONS

FULL CAPS





FINE MONO

GEOMETRIX I

GEOMETRIX II

GEOMETRIX V

OSCAR

H BOSS

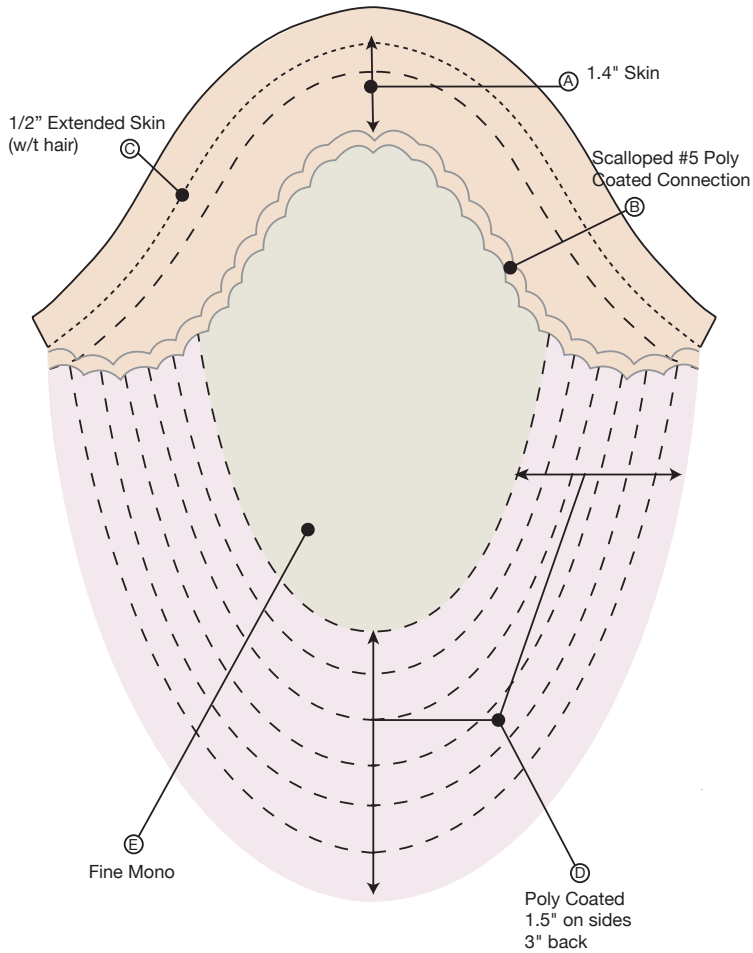

GEOMETRIX I

MSGMOH

BASE:

- Skin front
- 1/2" extended skin front without hair
- Fine mono center
- 1 1/2" poly coated on each side blending to 3" in back
- Scalloped #5 connection

SIZE:

- 8" x 10"
- Can be cut down to 5 1/2" x 7 1/2"

APPLICATION TYPE:

- Extended or daily wear

MAINTENANCE:

- Minimum 3-4 hair solutions per year

HAIR:

- Type: Human hair, gray is synthetic except 55Y, 65Y, 70Y, 80Y, 85Y, 90Y, 56Y, 57Y, 58Y, 59Y, 60RY where Yak is used (dark is synthetic)
- Length: 4" - 6"
- Wave Pattern: Light wave
- Density: Medium throughout, 10% less on sides & back
- Style: Freestyle

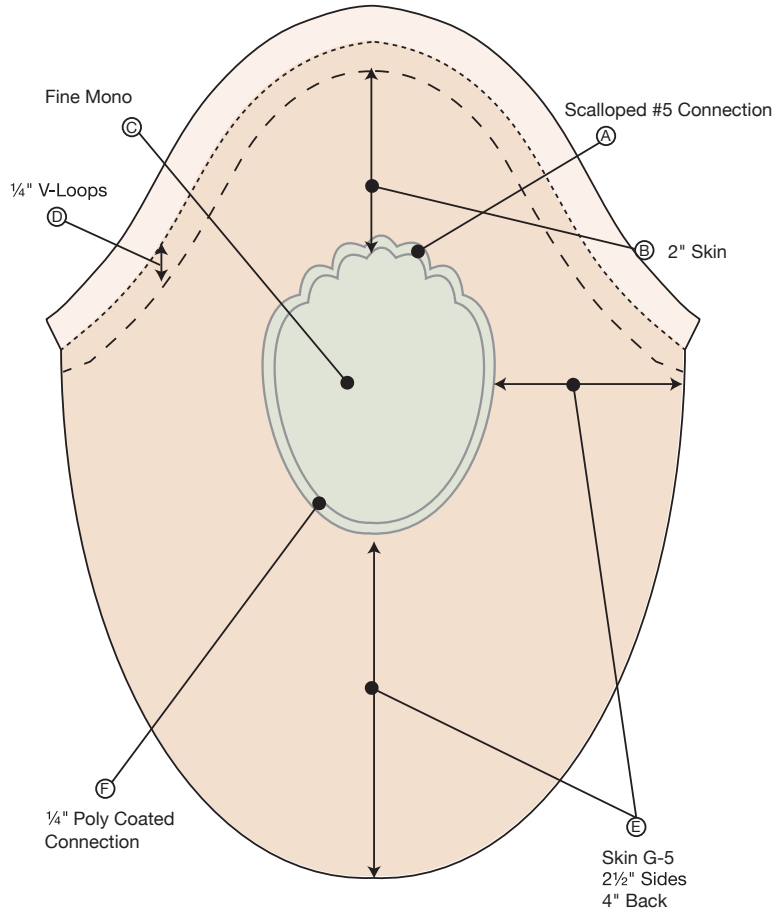

GEOMETRIX II

MSGMPVI

BASE:

- 2" skin front with 2 1/2" skin on each side extending to 4" in back
- 1/2" extended skin front without hair
- 3" x 4" fine mono center
- Scalloped #5 connection
- 1/4" v-loops in front

HAIR:

- Type: Human hair, gray is synthetic except 55Y, 65Y, 70Y, 80Y, 85Y, 90Y, 56Y, 57Y, 58Y, 59Y, 60RY where Yak is used (dark is synthetic)
- Length: 4" - 6"
- Wave Pattern: Light wave
- Density: Light to medium throughout, 10% less in front
- Style: Freestyle

SIZE:

- 8" x 10"
- Can be cut down to 3 1/2" x 4 1/2"

APPLICATION TYPE:

- Extended or daily wear
- *(Must use the NX-Gen Effects/x20/ ProExtreme Application Kit or warranty will be voided)*

MAINTENANCE:

- Minimum 3-4 hair solutions per year

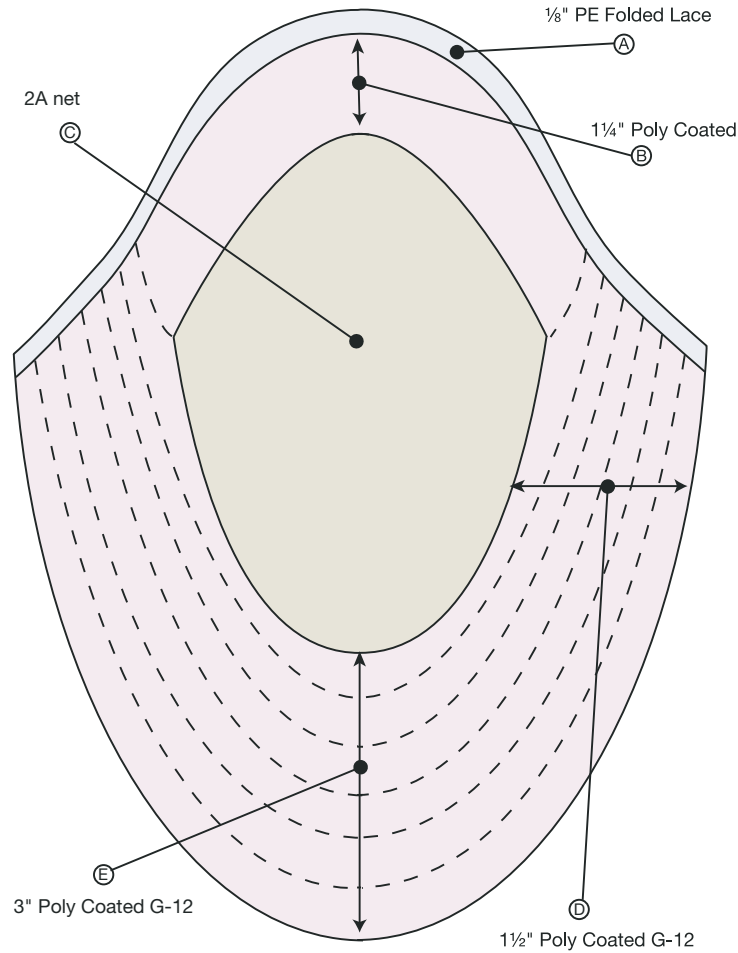

GEOMETRIX V

MSGMPH

BASE:

- 1/8" folded PE lace front
- Flexible nylon mesh
- Poly coated all around: 1 1/4" front, 1 1/2" each side, 3" back
- Patented stitched contour support lines

HAIR:

- Type: Human hair, gray is synthetic except 55Y, 65Y, 70Y, 80Y, 85Y, 90Y, 56Y, 57Y, 58Y, 59Y, 60RY where Yak is used (dark is synthetic)
- Length: 4" - 6"
- Wave Pattern: Light wave
- Density: Medium throughout, 10% less for sides and back
- Style: Freestyle

SIZE:

- 8" x 10"
- Can be cut down

APPLICATION TYPE:

- Extended or daily wear

MAINTENANCE:

- Minimum 2-3 hair solutions per year

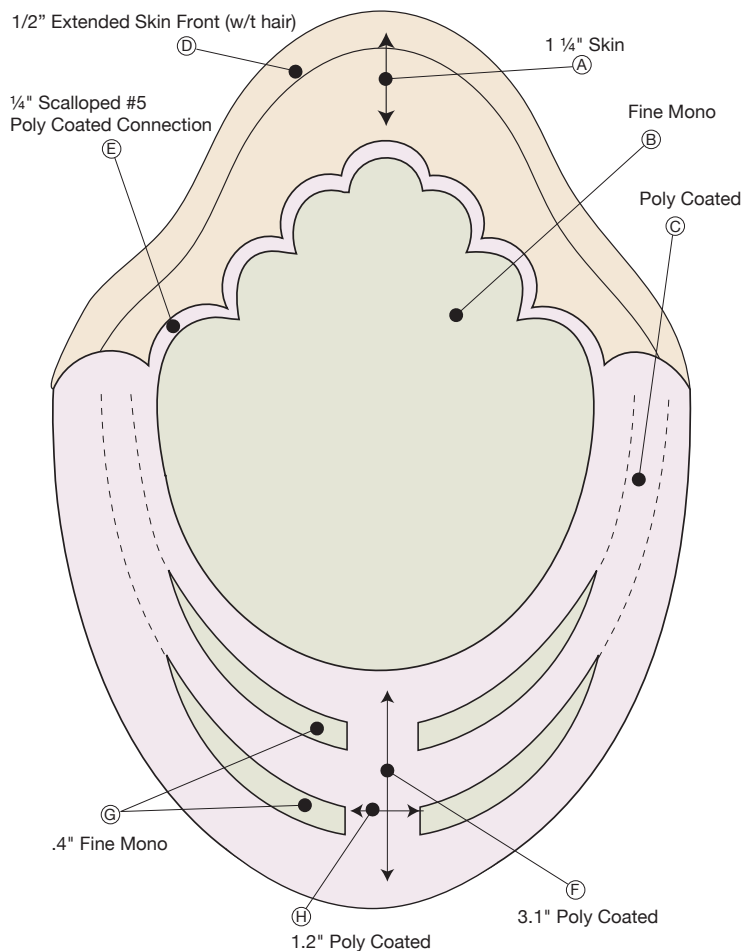

OSCAR

MS666CA

BASE:

- Skin front with 1/2" extended skin front without hair
- Scalloped #5 poly coated connection
- Fine mono center
- Poly coated cutaway lines

HAIR:

- Type: Human hair, gray is synthetic except 55Y, 65Y, 70Y, 80Y, 85Y, 90Y, 56Y, 57Y, 58Y, 59Y, 60RY where Yak is used (dark is synthetic)
- Length: 4 1/2" - 6 1/2"
- Wave Pattern: Light wave
- Density: Medium throughout
- Style: Freestyle

SIZE:

- 7 3/4" x 10 1/4", Can be cut down

APPLICATION TYPE:

- Extended or daily wear

MAINTENANCE:

- Minimum 2-3 hair solutions per year

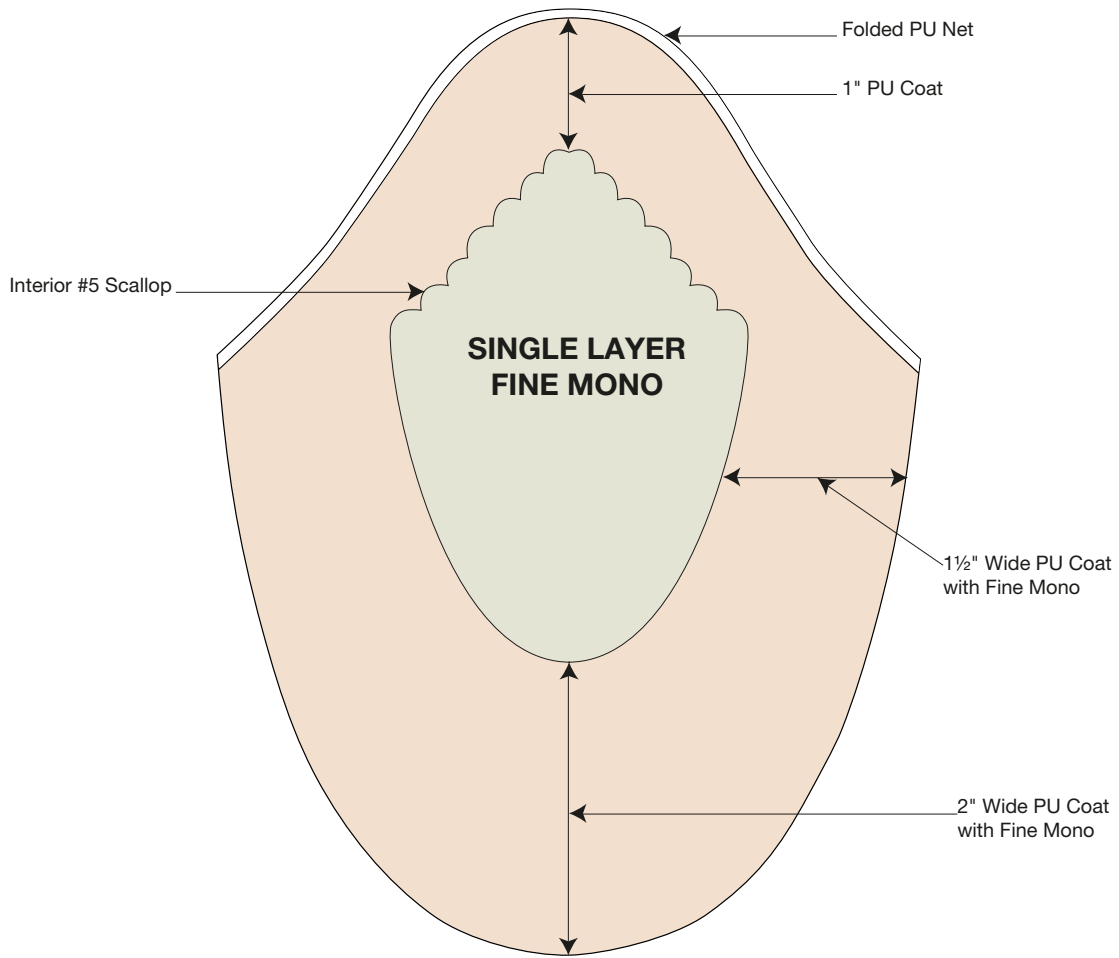

H-BOSS

MSHBOSS

BASE:

- 1/8" folded French lace front
- Fine mono center
- 1" PU coat in front blending to 1 1/2" on sides and 2" in back

HAIR:

- Type: Human hair, gray is synthetic except 55Y, 65Y, 70Y, 80Y, 85Y, 90Y, 56Y, 57Y, 58Y, 59Y, 60RY where Yak is used (dark is synthetic)
- Length: 4" - 6"
- Wave Pattern: Light wave
- Density: Medium throughout
- Style: Freestyle

SIZE:

- 8" X 9 3/4"
- Can be cut down

APPLICATION TYPE:

- Extended or daily wear

MAINTENANCE:

- Minimum 2-3 hair solutions per year





SWISS LACE

SWISS PLUS

SWISS PLUS II

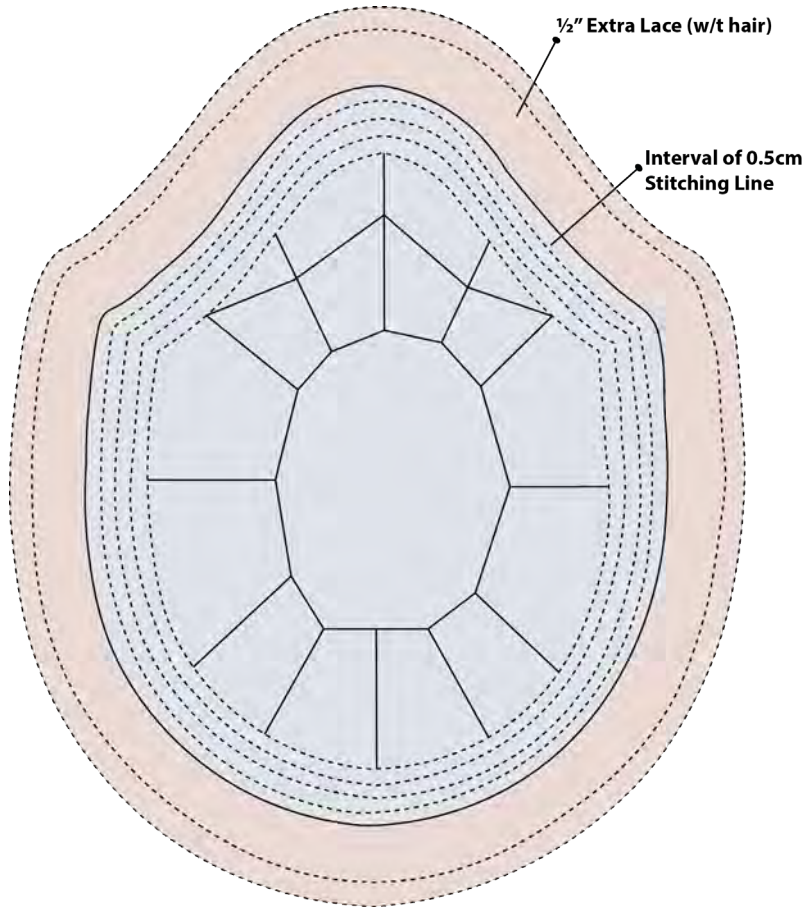

SWISS PLUS

MSSWISS+

BASE:

- Swiss Lace: Weightless and undetectable
- 1/2" extended lace without hair
- Colorless knots in front (colors 2-7, 7ASH, 6R and 8R, up to 20% gray)
- Patented stitched contour lines

HAIR:

- Type: Human hair, gray is synthetic except 55Y, 65Y, 70Y, 80Y, 85Y, 90Y, 56Y, 57Y, 58Y, 59Y, 60RY where Yak is used (dark is synthetic)
- Length: 6"
- Wave Pattern: Light wave
- Density: Light throughout, minus 10% in front
- Style: Freestyle

SIZE:

- 8" x 10", Can be cut down to any size

APPLICATION TYPE:

- Full head bonding only
- *(Must use the NX-Gen Effects/x20/ ProExtreme Application Kit or warranty will be voided)*

MAINTENANCE:

- Minimum 12-24 hair solutions per year

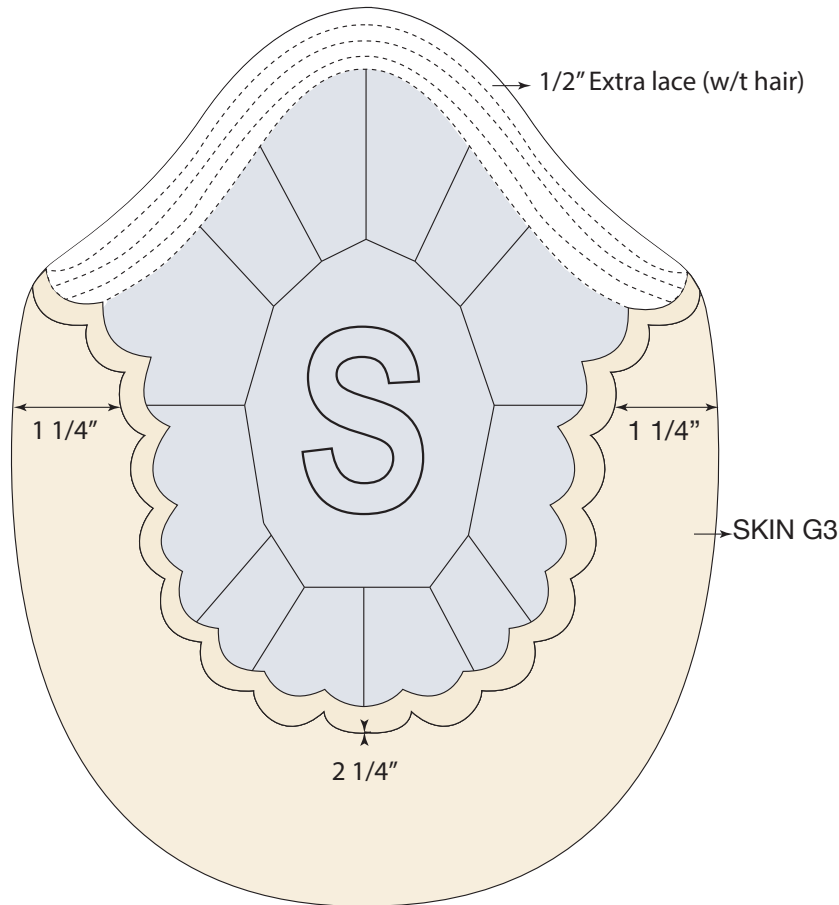

SWISS PLUS II

MSSWISS2+

BASE:

- Swiss lace center & front-weightless and undetectable
- 1/2" extended lace without hair
- Skin temple to temple around back
- Colorless knots in front (colors 2-7, 7ASH, 6R and 8R, up to 20% gray)

HAIR:

- Type: Human hair, gray is synthetic except 65Y, 80Y, and 60RY where Yak is used (dark is synthetic)
- Length: 6"
- Wave Pattern: Light wave
- Density: Light throughout, +5% skin area
- Style: Freestyle

SIZE:

- 8" x 10", Can be cut down to any size

APPLICATION TYPE:

- Full head bonding only
- *(Must use the NX-Gen Effects/x20/ ProExtreme Application Kit or warranty will be voided)*

MAINTENANCE:

- Minimum 12-24 hair solutions per year





FRENCH LACE

NX-GEN LACE

OCTAGON

QUANTUM I

QUANTUM VI

QUANTUM VI ELITE

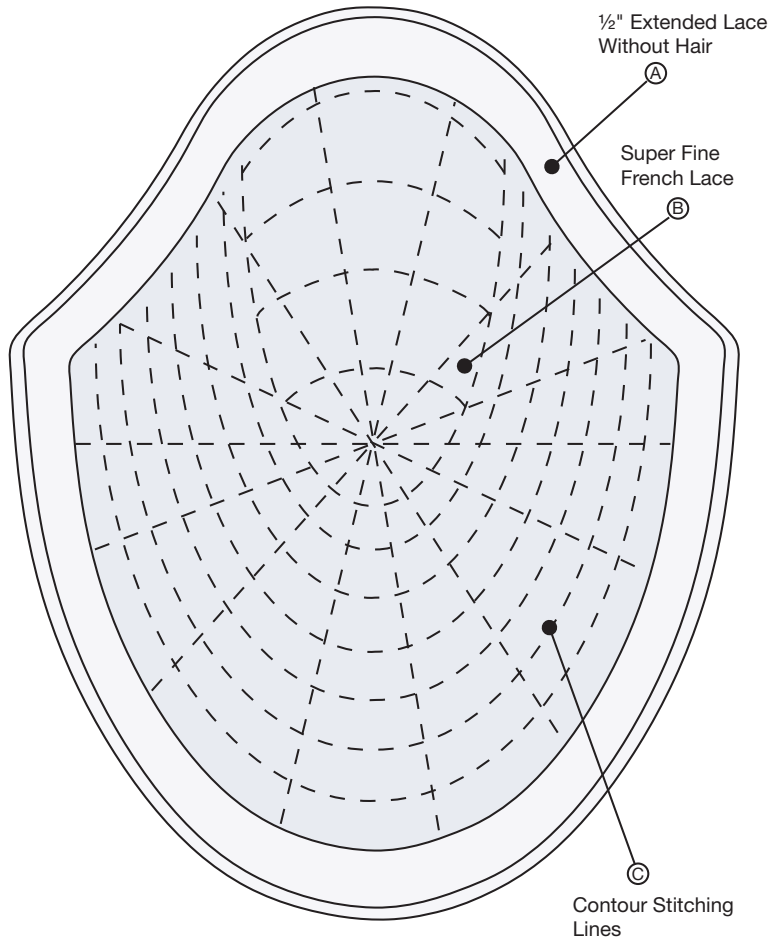

NX-GEN LACE

MSNXGLACE

BASE:

- Super fine French lace base, 1/2" extended super fine French lace around edge without hair
- Patented stitched contour support lines
- Colorless knots in front (colors 2-7, 7ASH, 6R & 8R, up to 20% gray)

HAIR:

- Type: Human hair, gray is synthetic except 55Y, 65Y, 70Y, 80Y, 85Y, 90Y, 56Y, 57Y, 58Y, 59Y, 60RY where Yak is used (dark is synthetic)
- Length: 6"
- Wave Pattern: Light wave
- Density: Light throughout, 10% less in front
- Style: Freestyle

SIZE:

- 8" x 10", Can be cut down to any size

APPLICATION TYPE:

- Full head bonding only
- *(Must use the NX-Gen Effects/x20/ ProExtreme Application Kit or warranty will be voided)*

MAINTENANCE:

- Minimum 12-18 hair solutions per year

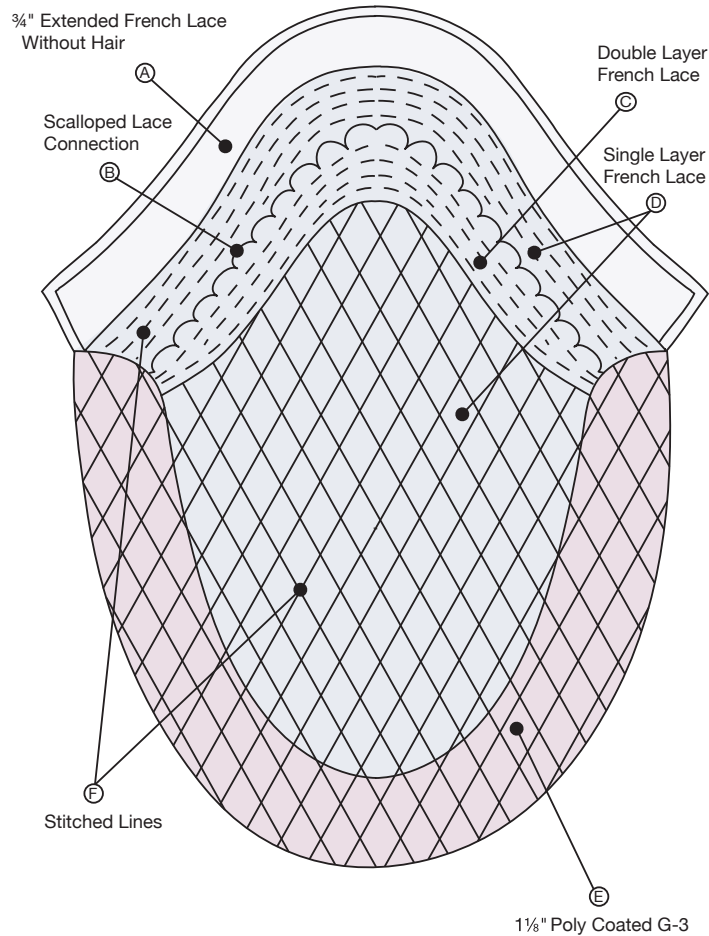

OCTAGON

MSOCT

BASE:

- All French lace base, 3/4" extended French lace without hair
- Interior double French lace layer with scalloped #5 tape tab area
- 1 1/8" Poly coated G-3 temple to temple around back
- Patented stitched contour support lines
- Colorless knots in front (colors 2-7, 7ASH, 6R & 8R, up to 20% gray)

HAIR:

- Type: Human hair, gray is synthetic except 55Y, 65Y, 70Y, 80Y, 85Y, 90Y, 56Y, 57Y, 58Y, 59Y, 60RY where Yak is used (dark is synthetic)
- Length: 4" - 6"
- Wave Pattern: Light wave
- Density: Light to medium throughout, 10% less in front
- Style: Freestyle

SIZE:

- 7 1/2" x 9 1/2", Can be cut down to any size

APPLICATION TYPE:

- Extended or daily wear

MAINTENANCE:

- Minimum 5-6 hair solutions per year

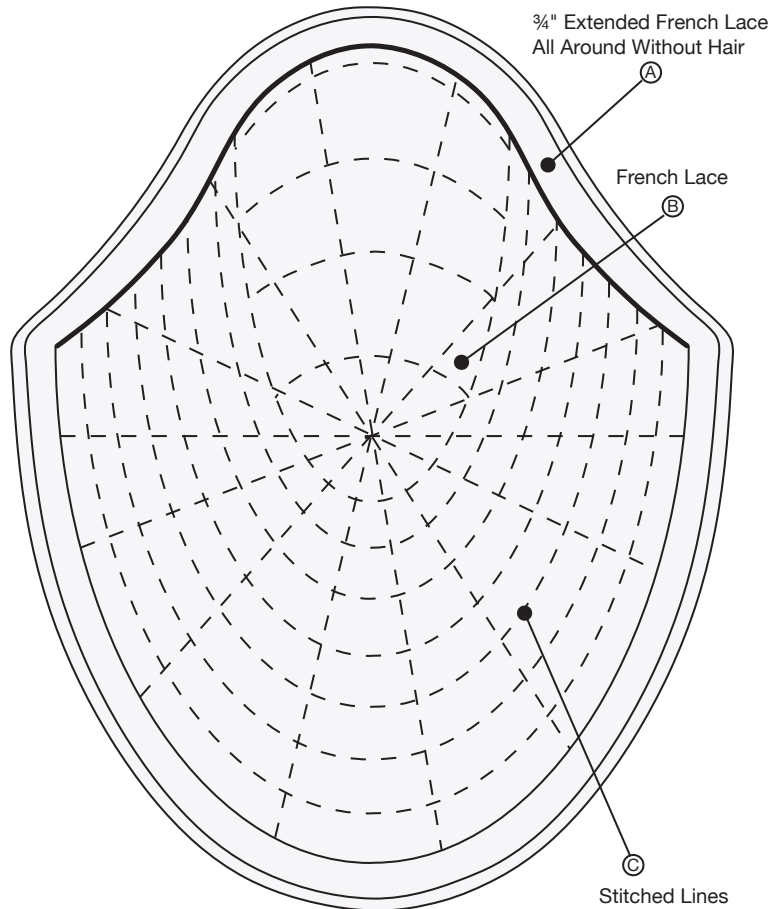

QUANTUM 1

MSQ1

BASE:

- French lace base, 1/2" extended French lace around edge without hair
- Patented stitched contour support lines
- Colorless knots in front (colors 2-7, 7ASH, 6R & 8R, up to 20% gray)

HAIR:

- Type: Human hair, gray is synthetic except 55Y, 65Y, 70Y, 80Y, 85Y, 90Y, 56Y, 57Y, 58Y, 59Y, 60RY where Yak is used (dark is synthetic)
- Length: 6"
- Wave Pattern: Light wave
- Density: Light throughout, 10% light in front
- Style: Freestyle

SIZE:

- 8" x 10", Can be cut down to any size

APPLICATION TYPE:

- Full head bonding only
- *(Must use the NX-Gen Effects/x20/ ProExtreme Application Kit or warranty will be voided)*

MAINTENANCE:

- Minimum 12-14 hair solutions per year

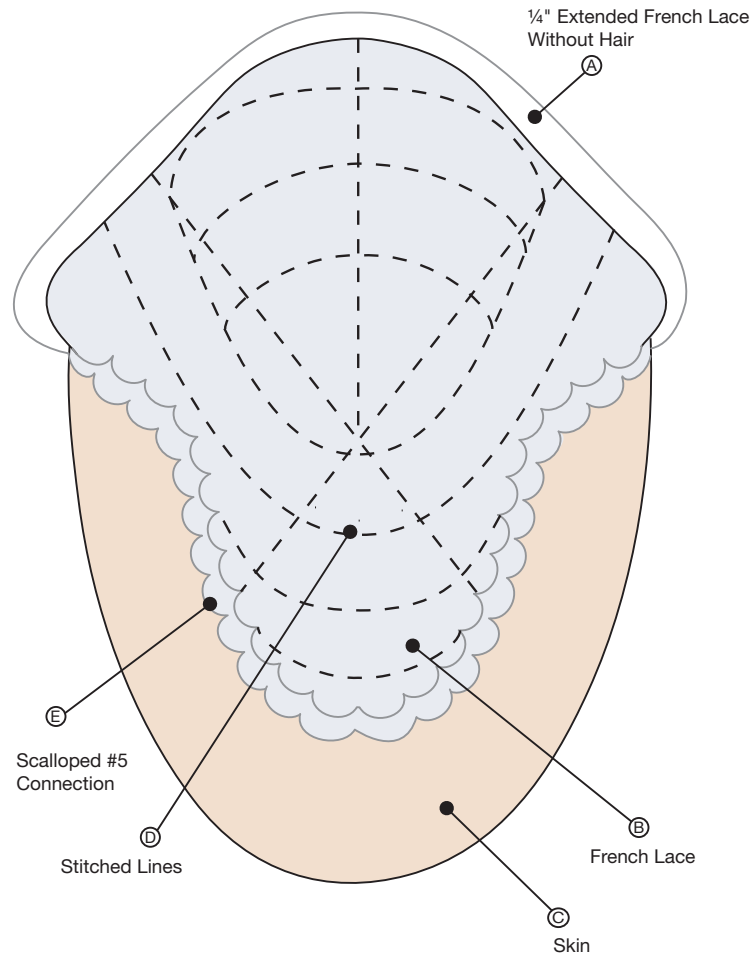

QUANTUM VI

MSQ6

BASE:

- French lace base, 1/4" extended French lace in front without hair, 1 1/4" skin on sides, 2" skin in back
- Patented stitched contour support lines, 1/4" scalloped connection
- Colorless knots in front (colors 2-7, 7ASH, 6R & 8R, up to 20% gray)

HAIR:

- Type: Human hair, gray is synthetic except 55Y, 65Y, 70Y, 80Y, 85Y, 90Y, 56Y, 57Y, 58Y, 59Y, 60RY where Yak is used (dark is synthetic)
- Length: 6"
- Wave Pattern: Light wave
- Density: Light to medium throughout, light in front
- Style: Freestyle

SIZE:

- 8" x 10", Can be cut down to any size

APPLICATION TYPE:

- Extended or daily wear

MAINTENANCE:

- Minimum 6-8 hair solutions per year

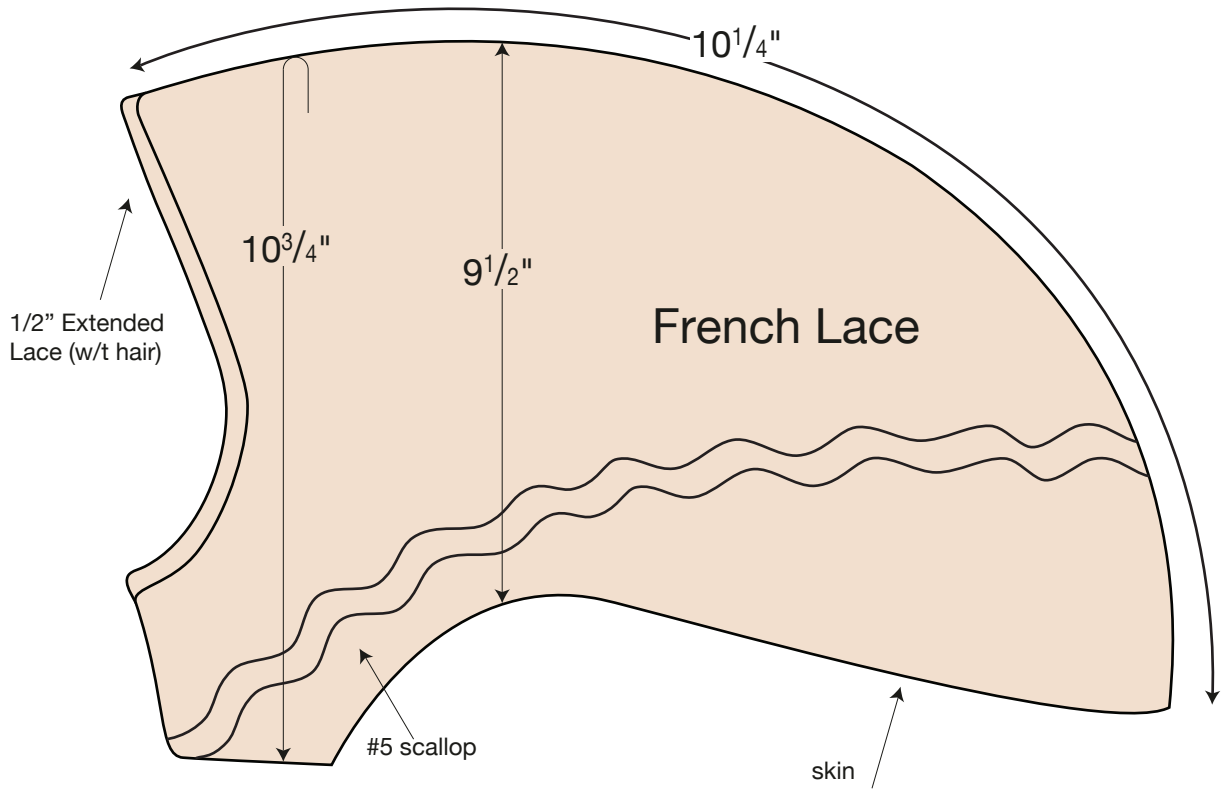

QUANTUM VI ELITE

MSMEQ6

BASE:

- French lace base, 1/2" extended French lace without hair
- Skin temple to temple around back
- Patented stitched contour support lines
- Colorless knots in front (colors 2-7, 7ASH, 6R & 8R, up to 20% gray)

HAIR:

- Type: Human hair, gray is synthetic except 55Y, 65Y, 70Y, 80Y, 85Y, 90Y, 56Y, 57Y, 58Y, 59Y, 60RY where Yak is used (dark is synthetic)
- Length: 6"
- Wave Pattern: Light wave
- Density: Light throughout, 10% light in front
- Style: Freestyle

SIZE:

- Front to back: 10 1/4"
- Temple to temple: 10 3/4"
- Ear to ear: 9 1/2"
- Can be cut down to any size

APPLICATION TYPE:

- Extended or daily wear

MAINTENANCE:

- Minimum 12-14 hair solutions per year

MAIN FEATURE:

- Ideal unit for creating side burns





WELDED LACE

ICON

ICONIC

ICON ELITE

QUANTUM V

PARAGON I PLUS

PARAGON II PLUS

PARAGON III PLUS

PARAGON EPIC

PENTAGON

PENTAGON II

SPECTRAGON

MILLENNIUM

MILLENNIUM ICONIC

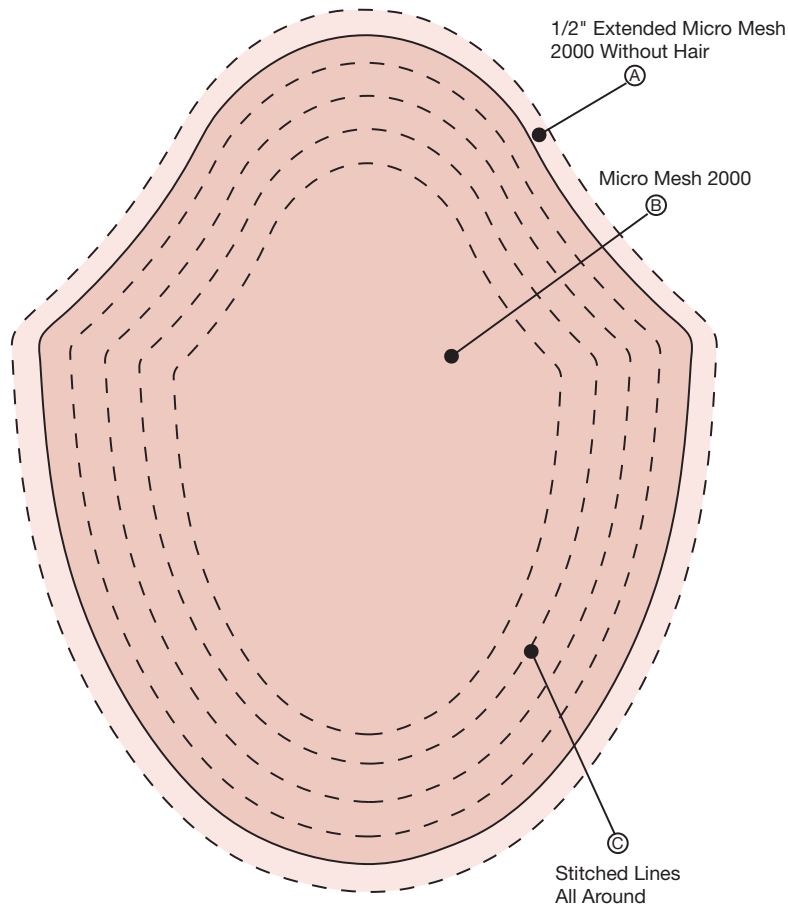

ICON

MSICON

BASE:

- Micro Mesh 2000: the finest and thinnest lace available - exclusive to New Image Labs
- 1/2" extended Micro Mesh 2000 without hair
- Patented stitched contour support lines
- Colorless knots in front (colors 2-7, 7ASH, 6R & 8R, up to 20% gray)

SIZE:

- 7 3/4" x 10 1/4", Can be cut down to any size

APPLICATION TYPE:

- Extended wear

MAINTENANCE:

- Minimum 6-8 hair solutions per year

HAIR:

- Type: Human hair, gray is synthetic except 55Y, 65Y, 70Y, 80Y, 85Y, 90Y, 56Y, 57Y, 58Y, 59Y, 60RY where Yak is used (dark is synthetic)
- Length: 6"
- Wave Pattern: Light wave
- Density: Extra light throughout, extra light in front
- Style: Freestyle

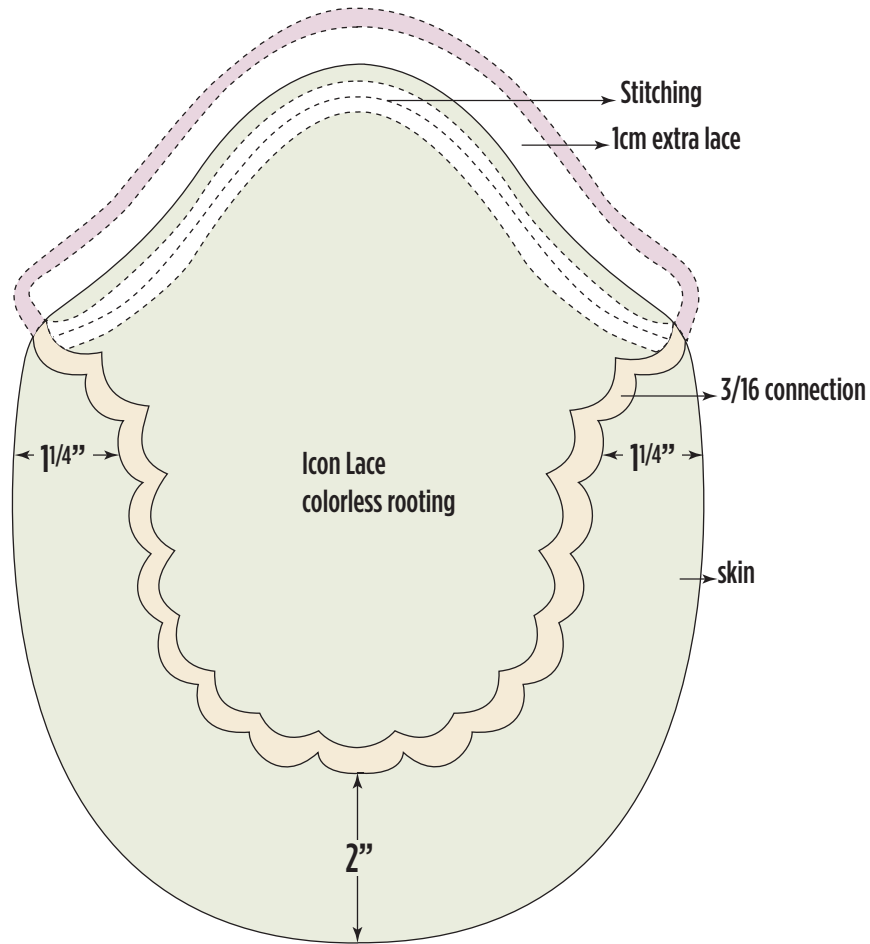

ICONIC

MSICONIC

BASE:

- Micro Mesh 2000: the finest and thinnest lace available - exclusive to New Image Labs
- Skin temple to temple around the back
- 1/2" extended lace without hair
- Patented stitched contour support lines
- Colorless knots in front (colors 2-7, 7ASH, 6R & 8R, up to 20% gray)

HAIR:

- Type: Human hair, gray is synthetic except 55Y, 65Y, 70Y, 80Y, 85Y, 90Y, 56Y, 57Y, 58Y, 59Y, 60RY where Yak is used (dark is synthetic)
- Length: 4" - 6"
- Wave Pattern: Light wave
- Density: Light to medium front, +5% throughout
- Style: Freestyle

SIZE:

- 8" x 10", Can be cut down to any size

APPLICATION TYPE:

- Extended or daily wear

MAINTENANCE:

- Minimum 6-8 hair solutions per year

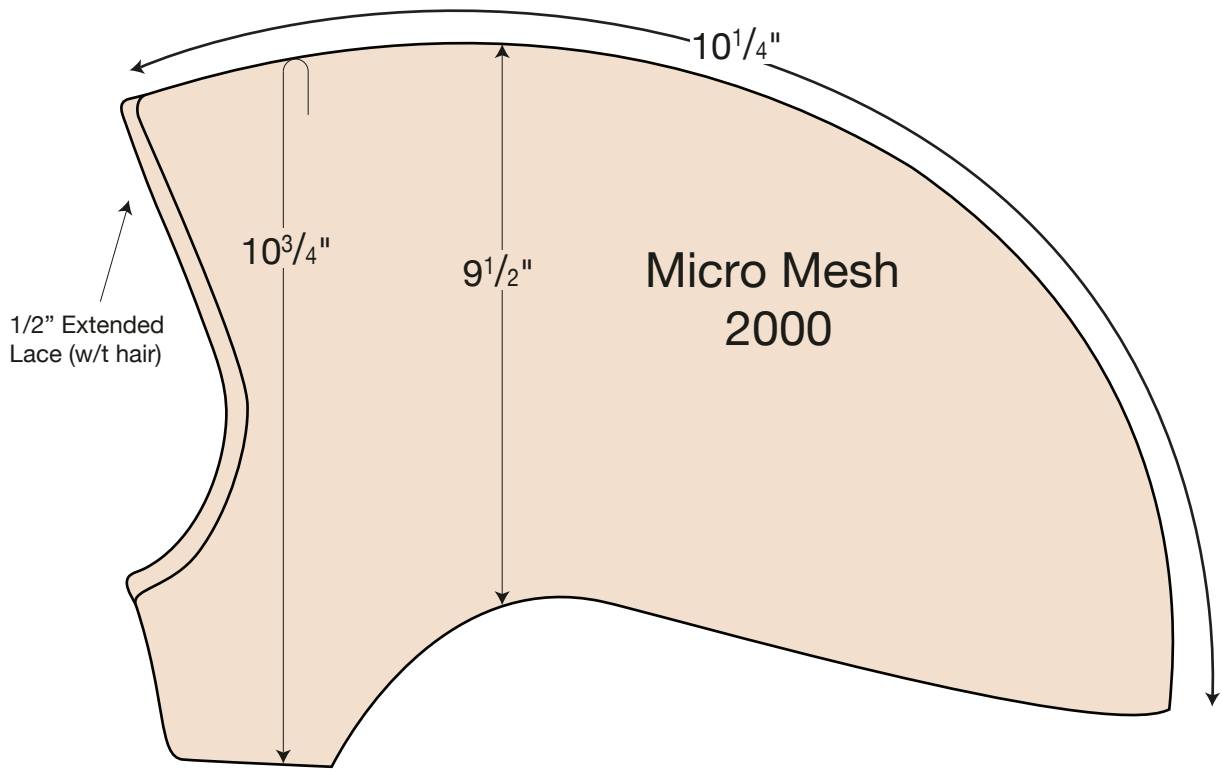

ICON ELITE

MSMEICON6

BASE:

- Micro Mesh 2000: the finest and thinnest lace available - exclusive to New Image Labs
- 1/2" Extended lace without hair
- Colorless knots in front (colors 2-7, 7ASH, 6R & 8R, up to 20% gray)

HAIR:

- Type: Human hair, gray is synthetic except 55Y, 65Y, 70Y, 80Y, 85Y, 90Y, 56Y, 57Y, 58Y, 59Y, 60RY where Yak is used (dark is synthetic)
- Length: 6"
- Wave Pattern: Light wave
- Density: Light throughout, extra light in temple
- Style: Freestyle

SIZE:

- Front to back: 10 1/4"
- Temple to temple: 10 3/4"
- Ear to ear: 9 1/2"
- Can be cut down to any size

APPLICATION TYPE:

- Extended wear

MAINTENANCE:

- Minimum 6-8 hair solutions per year

MAIN FEATURE:

- Ideal unit for creating side burns

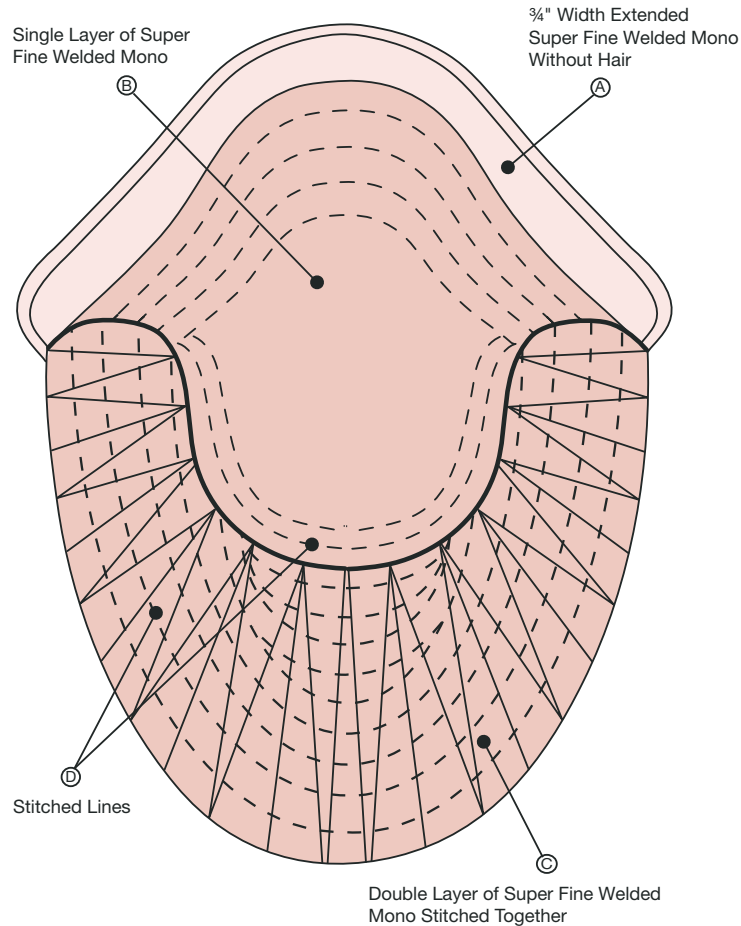

QUANTUM V

MSQ5

BASE:

- Super fine welded base with 3/4" extended front without hair
- Double layer super fine welded mono and stitched temple to temple around back
- Patented stitched contour support lines temple to temple around the backm@
- Colorless knots in front (colors 2-7, 7ASH, 6R & 8R, up to 20% gray)

HAIR:

- Type: Human hair, gray is synthetic except 55Y, 65Y, 70Y, 80Y, 85Y, 90Y, 56Y, 57Y, 58Y, 59Y, 60RY where Yak is used (dark is synthetic)
- Length: 5" - 6"
- Wave Pattern: Light wave
- Density: Light throughout, 10% less in front
- Style: Freestyle

SIZE:

- 8" x 10", Can be cut down to any size

APPLICATION TYPE:

- Extended or daily wear

MAINTENANCE:

- Minimum 4-6 hair solutions per year

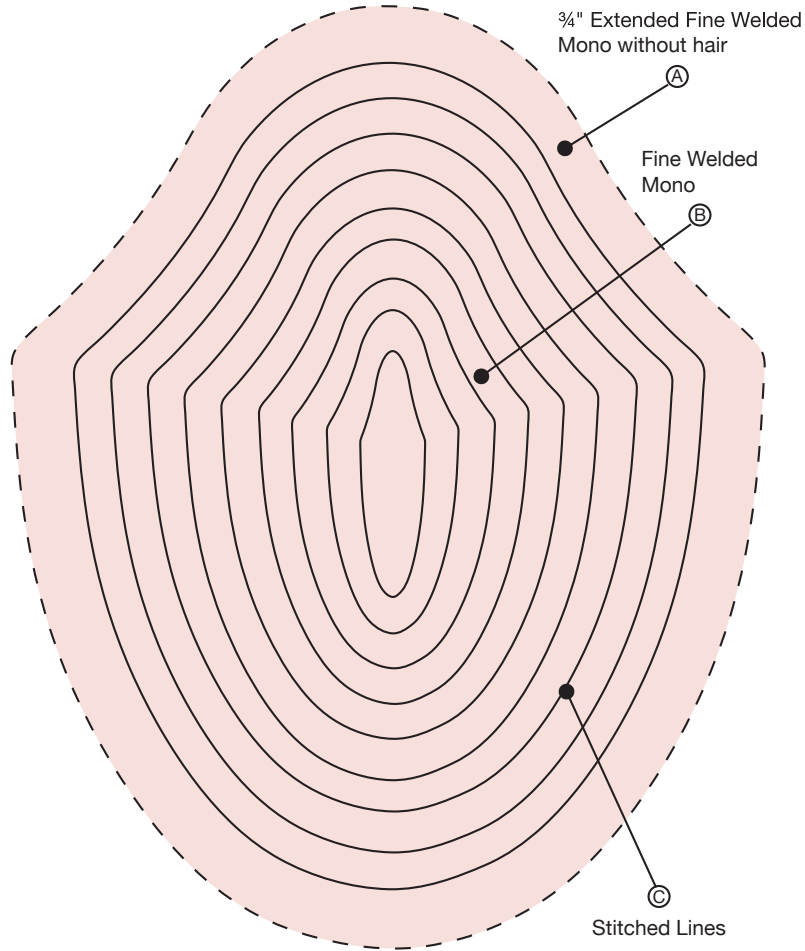

PARAGON I PLUS

MS6211+

BASE:

- Fine welded lace base
- 3/4" extended Fine Welded Mono without hair around perimeter
- Patented stitched contour support lines
- Colorless knots in front (colors 2-7, 7ASH, 6R & 8R, up to 20% gray)

HAIR:

- Type: Human hair, gray is synthetic except 55Y, 65Y, 70Y, 80Y, 85Y, 90Y, 56Y, 57Y, 58Y, 59Y, 60RY where Yak is used (dark is synthetic)
- Length: 6"
- Wave Pattern: Light wave
- Density: medium throughout, light/medium front
- Style: Freestyle

SIZE:

- 7 3/4" x 10 1/4",
- Can be cut down to any size

APPLICATION TYPE:

- Extended or daily wear

MAINTENANCE:

- Minimum 4-6 hair solutions per year

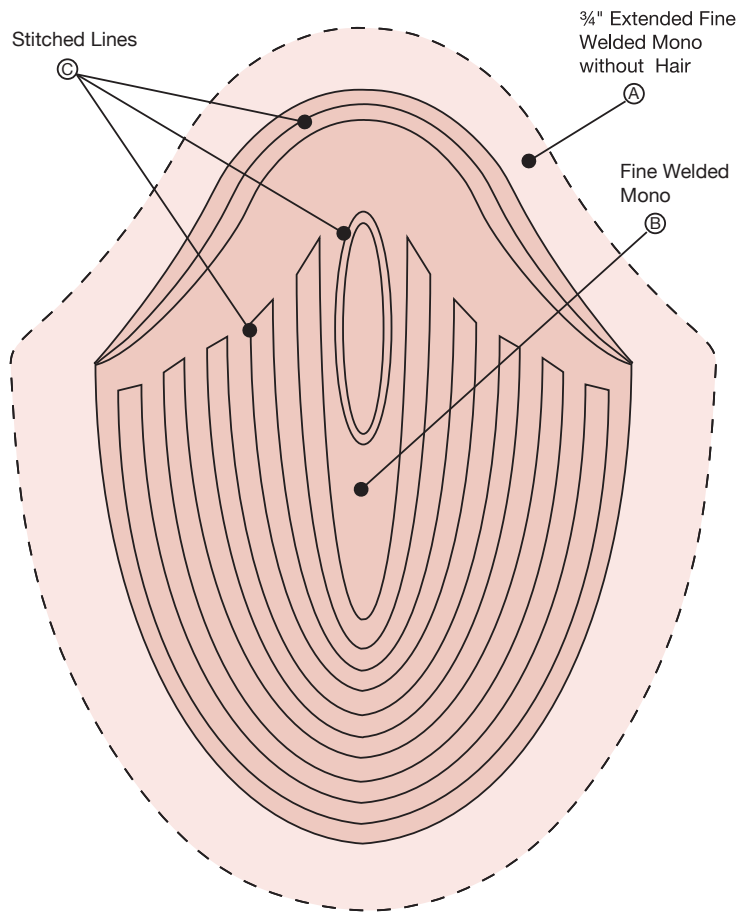

PARAGON II PLUS

MS6212+

BASE:

- Fine welded lace base
- 3/4" extended Fine Welded Mono without hair around perimeter
- Patented stitched contour support lines
- Colorless knots in front (colors 2-7, 7ASH, 6R & 8R, up to 20% gray)

HAIR:

- Type: Human hair, gray is synthetic except 55Y, 65Y, 70Y, 80Y, 85Y, 90Y, 56Y, 57Y, 58Y, 59Y, 60RY where Yak is used (dark is synthetic)
- Length: 6"
- Wave Pattern: Light wave
- Density: Light to medium throughout, light in front
- Style: Freestyle

SIZE:

- 7 3/4" x 10 1/4"
- Can be cut down to any size

APPLICATION TYPE:

- Extended or daily wear

MAINTENANCE:

- Minimum 4-6 hair solutions per year

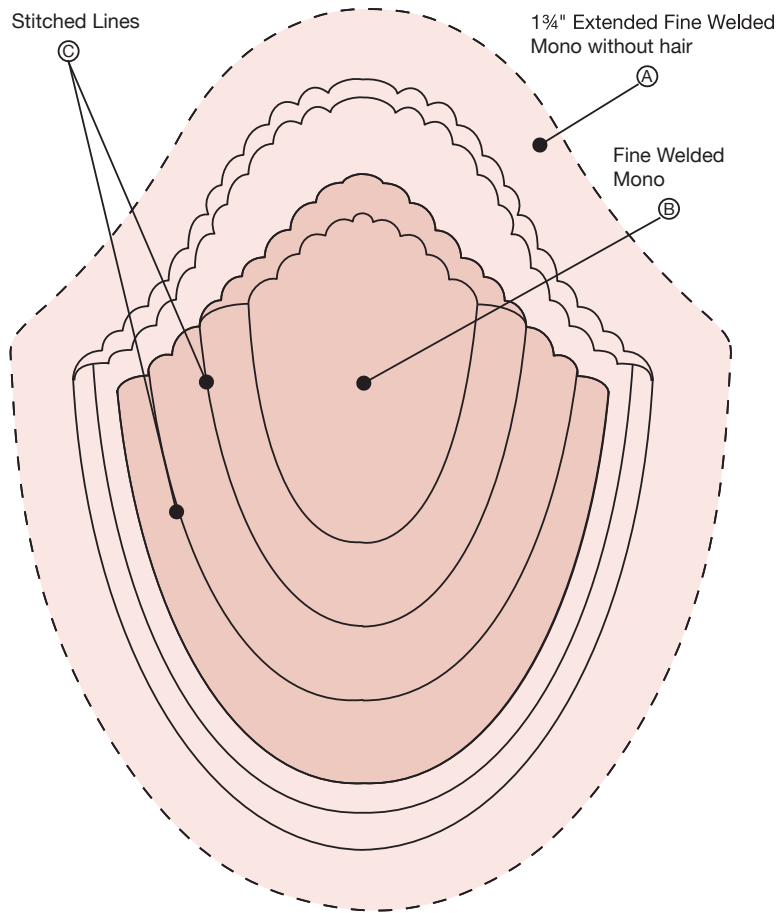

PARAGON III PLUS

MS6213+

BASE:

- Fine welded lace base
- 1 3/4" extended Fine Welded Mono without hair around perimeter
- Patented stitched contour support lines

HAIR:

- Type: Human hair, gray is synthetic except 55Y, 65Y, 70Y, 80Y, 85Y, 90Y, 56Y, 57Y, 58Y, 59Y, 60RY where Yak is used (dark is synthetic)
- Length: 6"
- Wave Pattern: Light wave
- Density: Light throughout, extra light in front
- Style: Freestyle

SIZE:

- 7 3/4" x 10 1/4",
- Can be cut down to any size

APPLICATION TYPE:

- Extended or daily wear

MAINTENANCE:

- Minimum 4-6 hair solutions per year

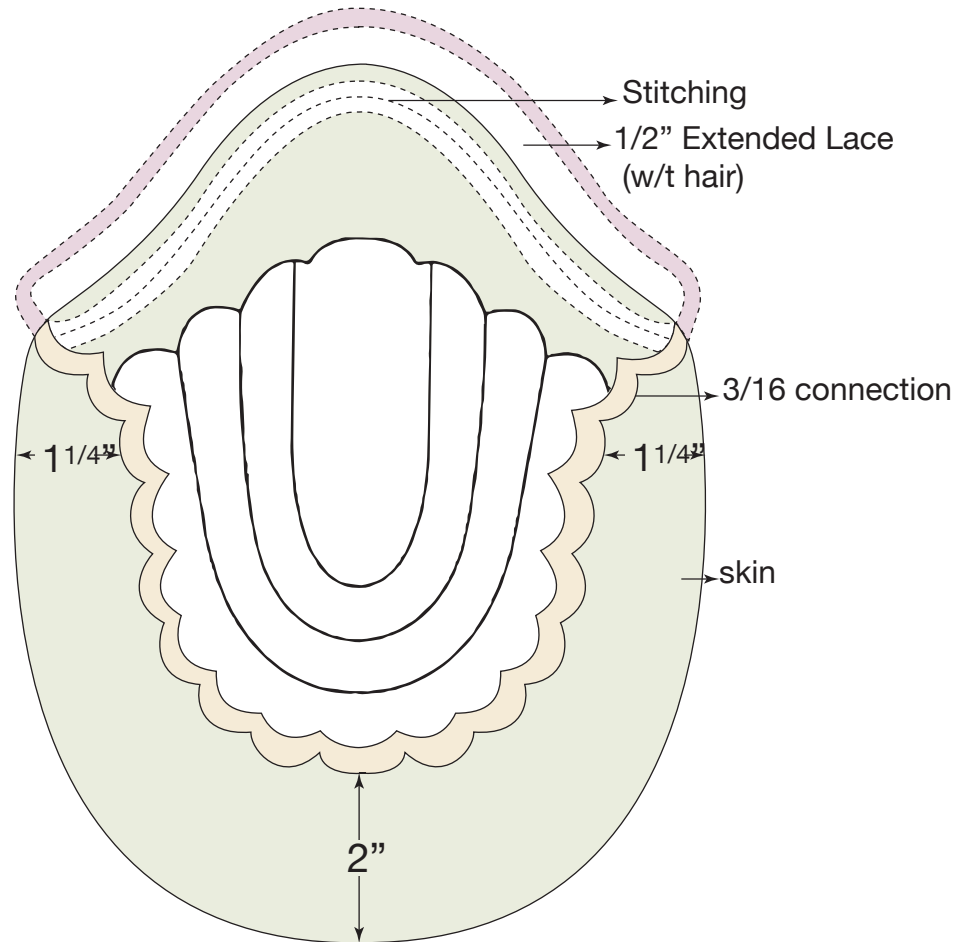

PARAGON EPIC

MSPARAE

BASE:

- Fine welded mono with
- 1/2" extended fine welded lace front without hair
- 1 1/4" skin temple to temple with 2" in back & 1/4" scalloped connection
- Entire fine welded area is colorless rooted

HAIR:

- Type: Human hair, gray is synthetic except 55Y, 65Y, 70Y, 80Y, 85Y, 90Y, 56Y, 57Y, 58Y, 59Y, 60RY where Yak is used (dark is synthetic)
- Length: 4" - 6"
- Wave Pattern: Light wave
- Density: Light to medium plus in front, +5% throughout
- Style: Freestyle

SIZE:

- 8" x 10", Can be cut down to any size

APPLICATION TYPE:

- Extended or daily wear

MAINTENANCE:

- Minimum 4-5 hair solutions per year

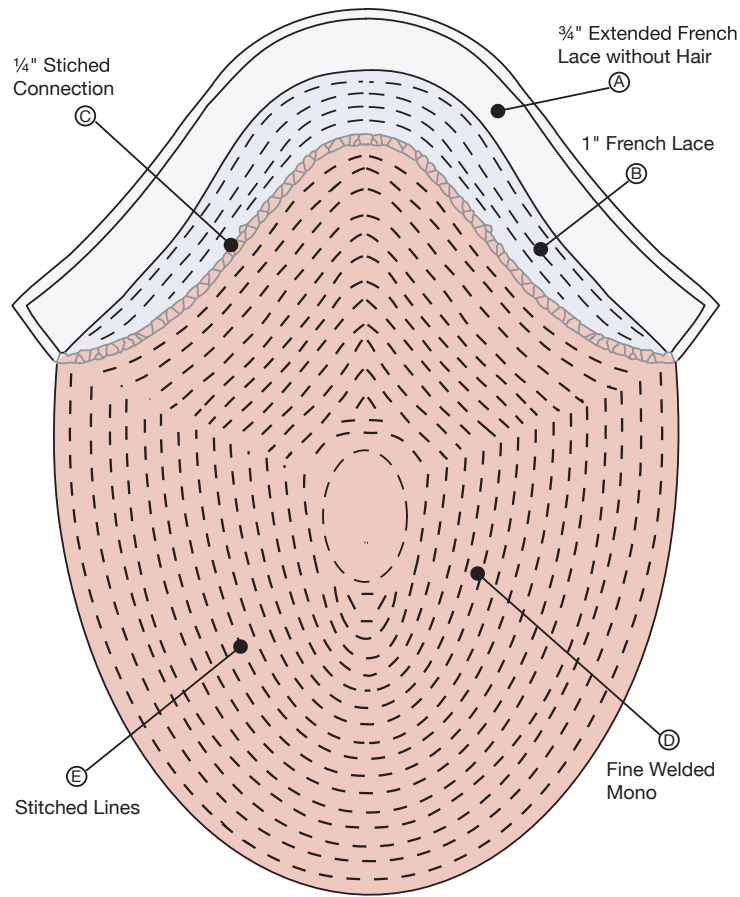

PENTAGON

MSPENT+

BASE:

- 1" French lace front
- 3/4" extended French lace without hair
- Fine welded lace base center
- Patented stitched support lines
- Colorless knots in front (colors 2-7, 7ASH, 6R & 8R, up to 20% gray)

HAIR:

- Type: Human hair, gray is synthetic except 65Y, 80Y, and 60RY where Yak is used (dark is synthetic)
- Length: 4 - 6"
- Wave Pattern: Light wave
- Density: Light to medium throughout, 10% less in front
- Style: Freestyle

SIZE:

- 7 3/4" x 10 1/4"
- Can be cut down any size

APPLICATION TYPE:

- Extended or daily wear

MAINTENANCE:

- Minimum 4-6 hair solutions per year

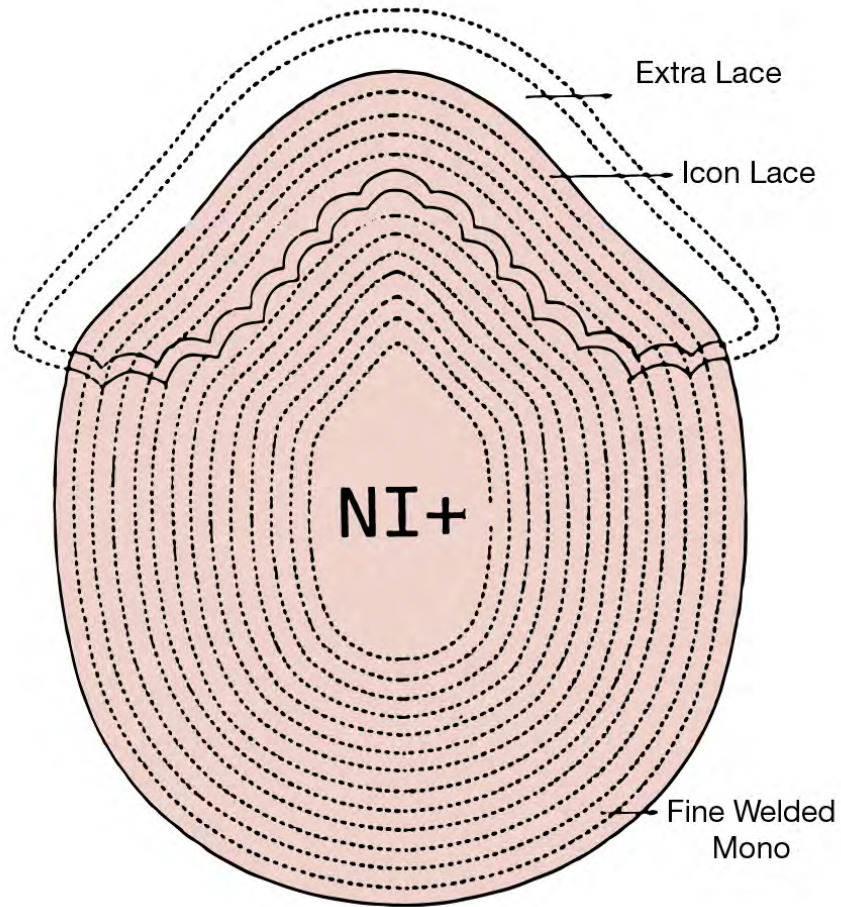

PENTAGON II

MSPENT2+

BASE:

- 1" Icon lace front
- 1/2" extended Icon lace without hair
- Scalloped #5 connection
- Fine welded lace base center
- Patented stitched support lines
- Colorless knots in front (colors 2-7, 7ASH, 6R & 8R, up to 20% gray)

HAIR:

- Type: Human hair, gray is synthetic except 65Y, 80Y and 60RY where Yak is used (dark is synthetic)
- Length: 6"
- Wave Pattern: Light wave
- Density: Light to medium throughout
- Style: Freestyle

SIZE:

- 8" x 10 1/4"
- Can be cut down any size

APPLICATION TYPE:

- Extended or daily wear

MAINTENANCE:

- Minimum 3-4 hair solutions per year

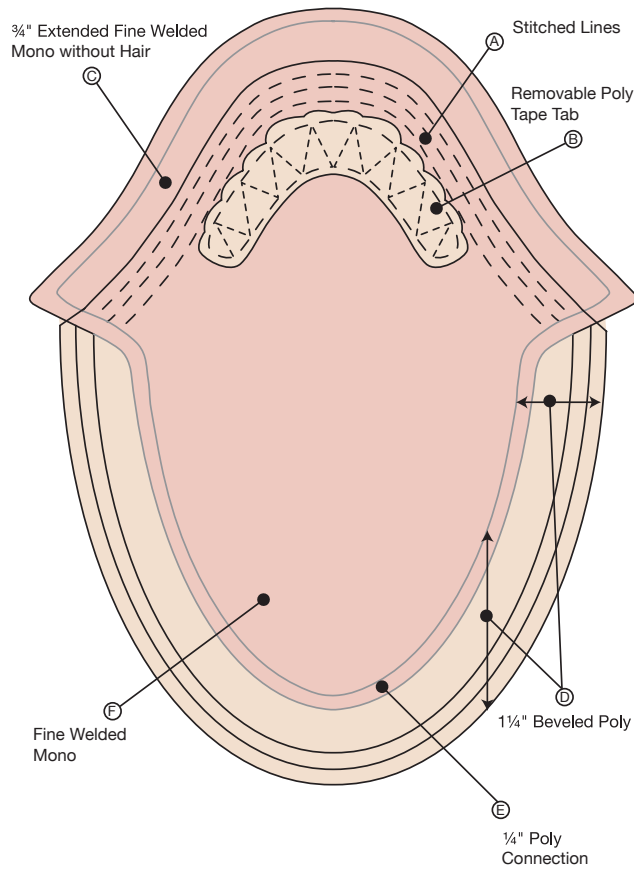

SPECTRAGON

MS6585, MS7595

BASE:

- Fine welded lace base
- 3/4" extended fine welded lace front
- 1 1/4" beveled polyurethane edge on sides and back for a virtually seamless edge
- Removable interior scalloped poly tape tab in front
- Colorless knots in front (colors 2-7, 7ASH, 6R & 8R, up to 20% gray)

HAIR:

- Type: Human hair, gray is synthetic except 55Y, 65Y, 70Y, 80Y, 85Y, 90Y, 56Y, 57Y, 58Y, 59Y, 60RY where Yak is used (dark is synthetic)
- Length: 6"
- Wave Pattern: Light wave
- Density: Light to medium throughout, light in front
- Style: Freestyle

SIZE:

- 6 1/2" x 8 1/2" OR 7 1/2" x 9 1/2"
- Can be cut down to any size

APPLICATION TYPE:

- Daily wear

MAINTENANCE:

- Minimum 4-6 hair solutions per year

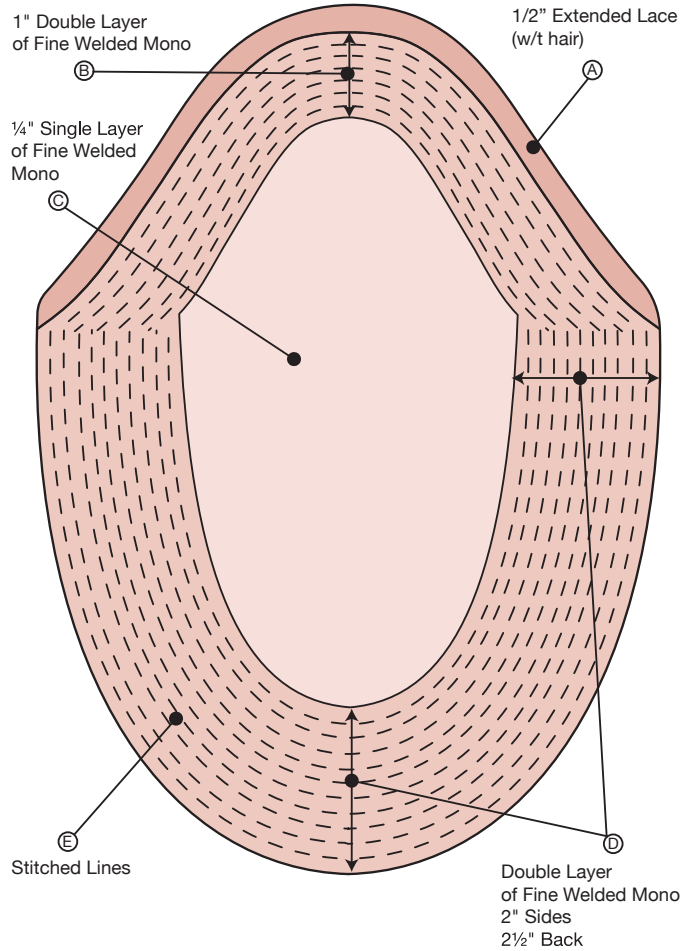

MILLENNIUM

MS2000

BASE:

- All fine welded base
- 1/2" extended fine welded lace front without hair
- Double layer fine welded mono around perimeter
- Patented stitched contour support lines
- Colorless knots in front (Colors 2-7, 7ASH, 6R & 8R, up to 20% gray)

HAIR:

- Type: Human hair, gray is synthetic except 55Y, 65Y, 70Y, 80Y, 85Y, 90Y, 56Y, 57Y, 58Y, 59Y, 60RY where Yak is used (dark is synthetic)
- Length: 5" - 6"
- Wave Pattern: Light wave
- Density: Light throughout, extra light to light in front
- Style: Freestyle

SIZE:

- 7 1/2" x 9 3/4"
- Can be cut down to any size

APPLICATION TYPE:

- Extended or dail wear

MAINTENANCE:

- Minimum 3-4 hair solutions per year

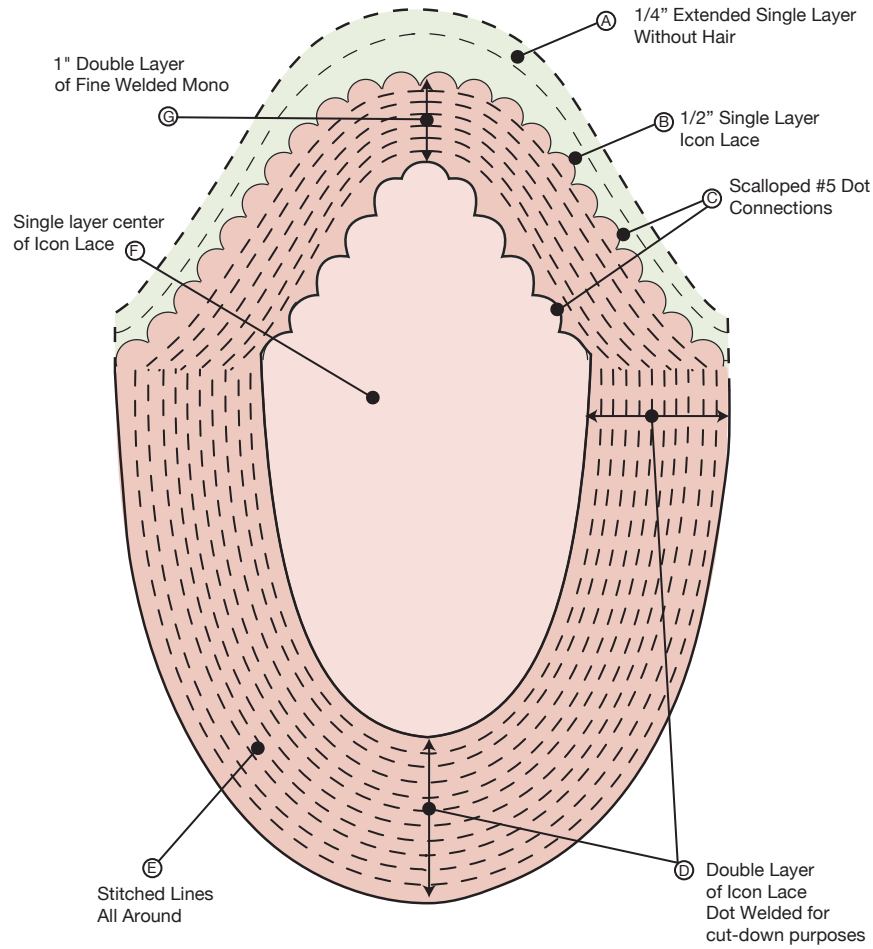

MILLENNIUM ICONIC

MS2000IC

BASE:

- Icon lace base
- 1/4" extended fine welded lace front without hair
- 1" Double layer fine welded mono around perimeter
- Patented stitched contour support lines
- Colorless knots in front (Colors 2-7, 7ASH, 6R & 8R, up to 20% gray)

HAIR:

- Type: Human hair, gray is synthetic except 55Y, 65Y, 70Y, 80Y, 85Y, 90Y, 56Y, 57Y, 58Y, 59Y, 60RY where Yak is used (dark is synthetic)
- Length: 6"
- Wave Pattern: Light wave
- Density: Light to medium front, medium throughout
- Style: Freestyle

SIZE:

- 8 1/2" x 11"
- Can be cut down to any size

APPLICATION TYPE:

- Extended or daily wear

MAINTENANCE:

- Minimum 3-4 hair solutions per year





SKIN

NX-GEN SKIN

GEOMETRIX VI

XTS

XTS EPIC

XTS ELITE

XT3

POLYGRAFT II

QUANTUM II

RANDY EPIC

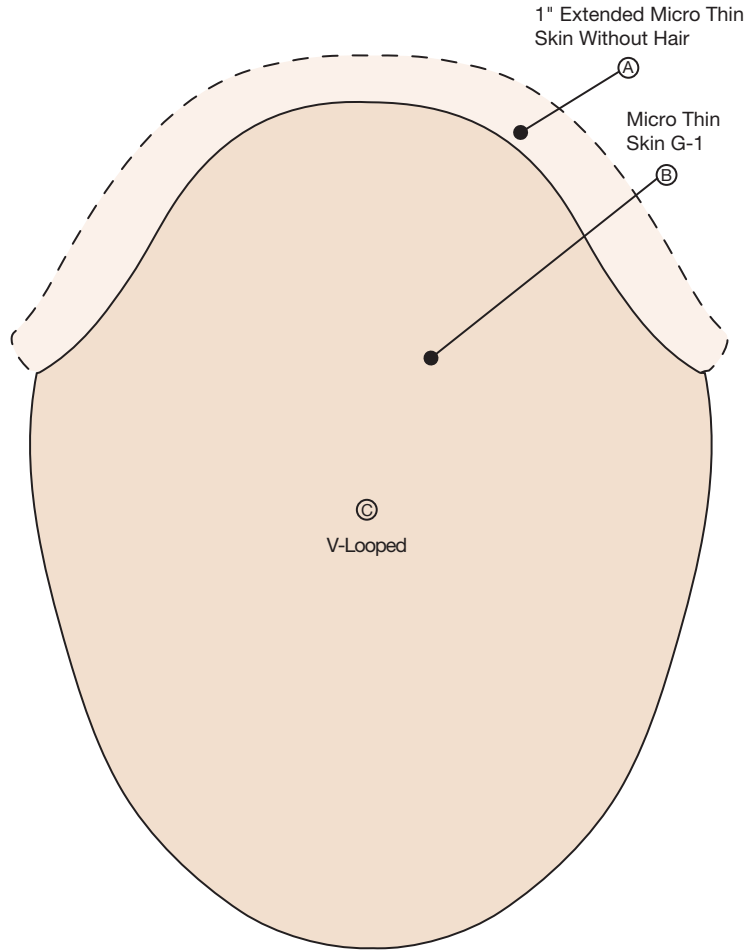

NX-GEN SKIN

MSNXGSKIN

BASE:

- Extra thin skin base
- 1/2" extended skin front without hair
- U-loop
- No cleanup, no repairs, & no oxidation as a "throw-away" unit

HAIR:

- Type: Human hair, gray is synthetic except 55Y, 65Y, 70Y, 80Y, 85Y, 90Y, 56Y, 57Y, 58Y, 59Y, 60RY where Yak is used (dark is synthetic)
- Length: 4" - 6"
- Wave Pattern: Light wave
- Density: Light to medium throughout, 5% less in front
- Style: Freestyle

SIZE:

- 7 1/4" x 9 1/2", Can be cut down to any size

APPLICATION TYPE:

- Full head bonding only
- *(Must use the NX-Gen Effects/x20/ ProExtreme Application Kit or warranty will be voided)*

MAINTENANCE:

- Minimum 12-24 hair solutions per year

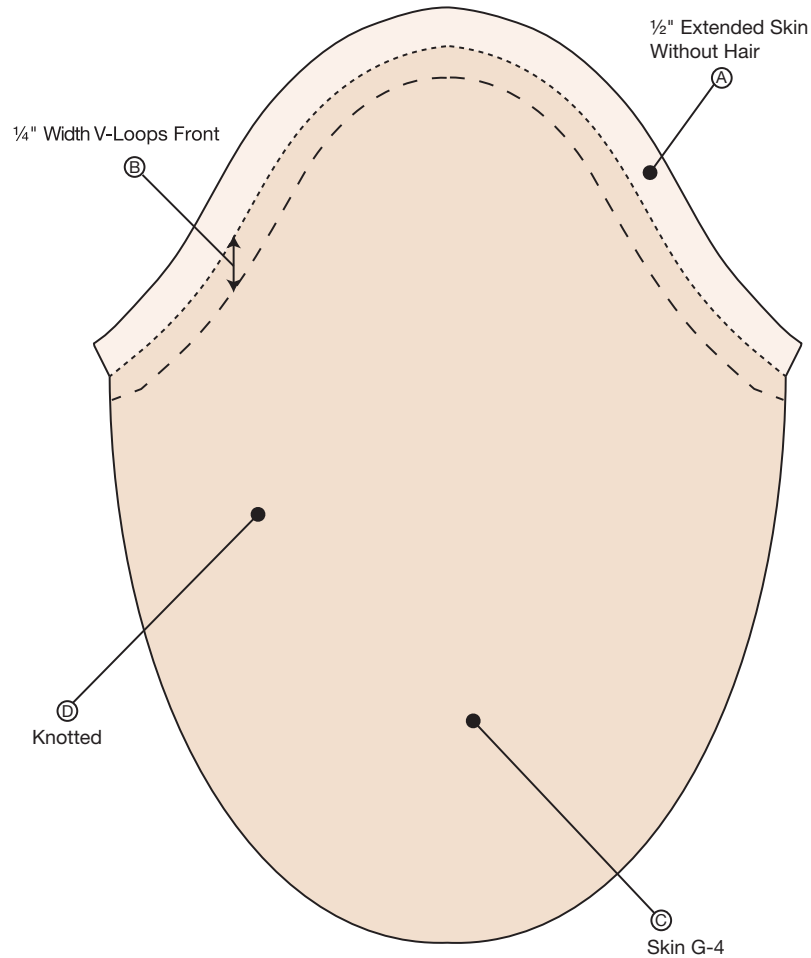

GEOMETRIX VI

MSGMTS

BASE:

- Extra thin skin base
- 1/2" extended skin front without hair
- 1/2" width v-loop in front
- Knotted throughout

HAIR:

- Type: Human hair, gray is synthetic except 55Y, 65Y, 70Y, 80Y, 85Y, 90Y, 56Y, 57Y, 58Y, 59Y, 60RY where Yak is used (dark is synthetic)
- Length: 4"-6"
- Wave Pattern: Light wave throughout
- Density: Light to medium throughout, 5% less in front
- Style: Freestyle

SIZE:

- 8" x 10", can be cut down to any size

APPLICATION TYPE:

- Extended wear
- *(Must use the NX-Gen Effects/x20/ ProExtreme Application Kit or warranty will be voided)*

MAINTENANCE:

- Minimum 5-8 hair solutions per year

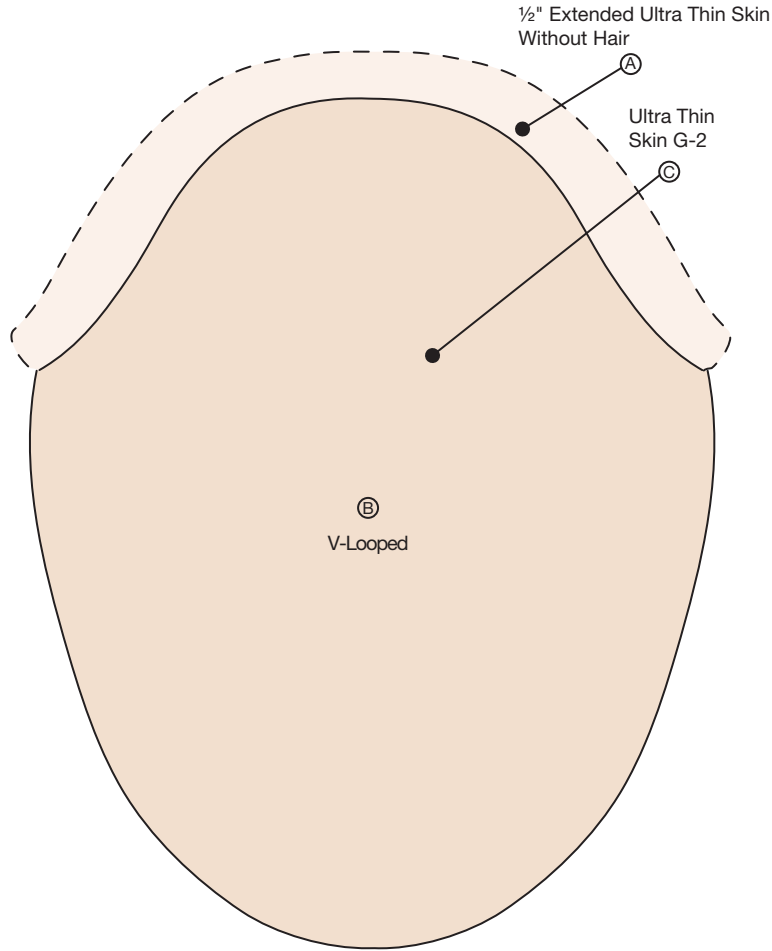

XTS

MSXTS

BASE:

- Ultra-thin skin base
- 1/2" extended thin skin without hair
- V-looped throughout
- No cleanup, no repairs, & no oxidation as a "throw-away" unit

HAIR:

- Type: Human hair, gray is synthetic except 55Y, 65Y, 70Y, 80Y, 85Y, 90Y, 56Y, 57Y, 58Y, 59Y, 60RY where Yak is used (dark is synthetic)
- Length: 4" - 6"
- Wave Pattern: Light wave
- Density: Light throughout, +5% throughout
- Style: Freestyle

SIZE:

- 8" x 10"
- Can be cut down to any size

APPLICATION TYPE:

- Full head bonding only
- *(Must use the NX-Gen Effects/x20/ ProExtreme Application Kit or warranty will be voided)*

MAINTENANCE:

- Minimum 12-18 hair solutions per year

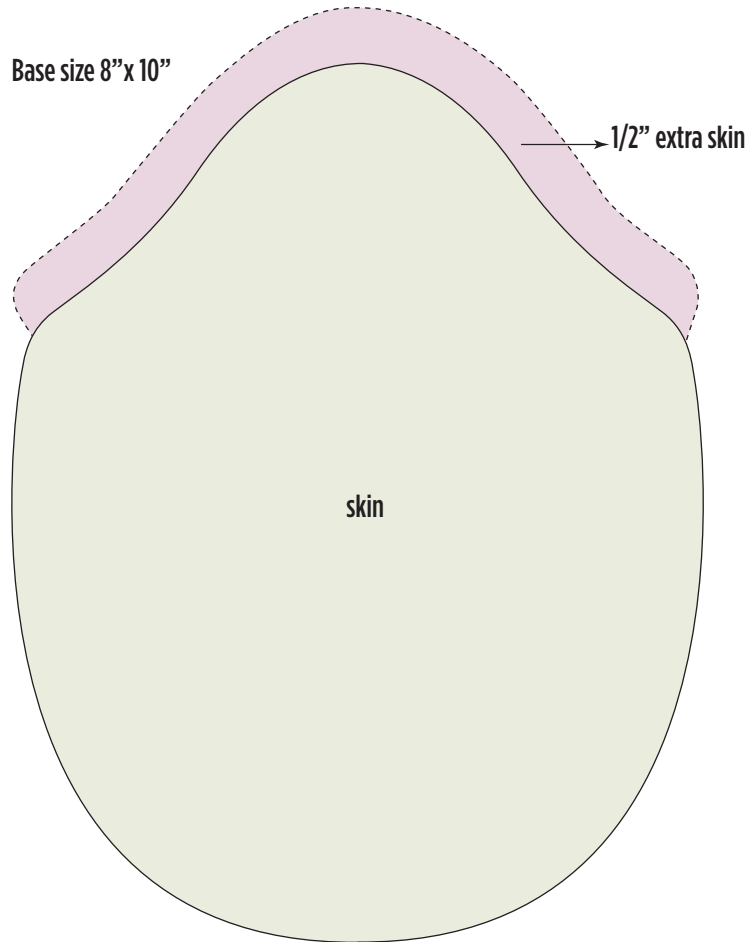

XTS EPIC

MSXTSE

BASE:

- Extra thin skin base
- Extended skin without hair
- Knotted throughout
- No cleanup, no repairs, & no oxidation as a “throw-away” unit

HAIR:

- Type: Human hair, gray is synthetic except 55Y, 65Y, 70Y, 80Y, 85Y, 90Y, 56Y, 57Y, 58Y, 59Y, 60RY where Yak is used (dark is synthetic)
- Length: 4” - 6”
- Wave Pattern: Light wave
- Density: Light to medium front, +5% for rest
- Style: Freestyle

SIZE:

- 8” x 10”, Can be cut down to any size

APPLICATION TYPE:

- Full head bonding only
- *(Must use the NX-Gen Effects/x20/ ProExtreme Application Kit or warranty will be voided)*

MAINTENANCE:

- Minimum 6-8 hair solutions per year

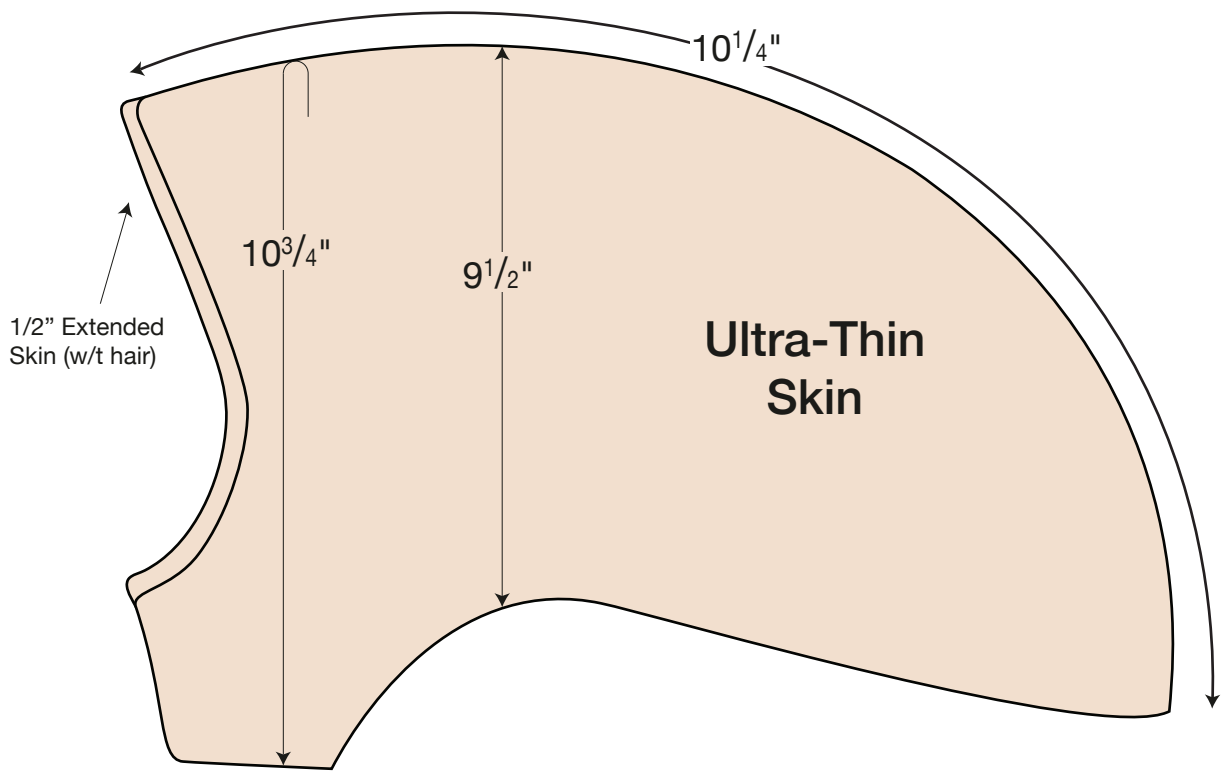

XTS ELITE

MSMEXTS

BASE:

- Ultra-thin skin base
- 1/2" extended thin skin front without hair

HAIR:

- Type: Human hair, gray is synthetic except 55Y, 65Y, 70Y, 80Y, 85Y, 90Y, 56Y, 57Y, 58Y, 59Y, 60RY where Yak is used (dark is synthetic)
- Length: 6"
- Wave Pattern: Light wave
- Density: Light throughout, +5% throughout
- Style: Freestyle

SIZE:

- Front to back: 10"
- Temple to temple: $10\frac{3}{4}"$
- Ear to ear: $9\frac{1}{2}"$

APPLICATION TYPE:

- Full head bonding only
- *(Must use the NX-Gen Effects/x20/ ProExtreme Application Kit or warranty will be voided)*

MAINTENANCE:

- Minimum 12-18 hair solutions per year

MAIN FEATURE:

- Can be used to create side burns

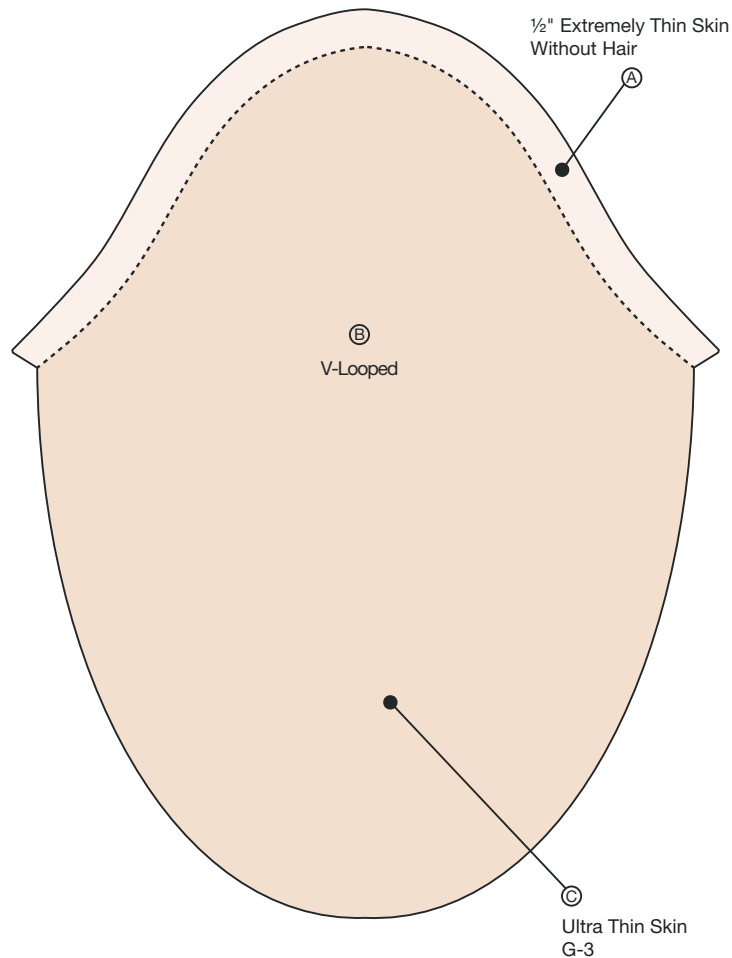

XT3

MSXT3

BASE:

- Ultra-thin skin base
- 1/2" extended thin skin without hair
- V-looped throughout
- No cleanup, no repairs, & no oxidation as a "throw-away" unit

HAIR:

- Type: Human hair, gray is synthetic except 55Y, 65Y, 70Y, 80Y, 85Y, 90Y, 56Y, 57Y, 58Y, 59Y, 60RY where Yak is used (dark is synthetic)
- Length: 4" - 6"
- Wave Pattern: Light wave
- Density: Light throughout, plus 5%
- Style: Freestyle

SIZE:

- 8" x 10", Can be cut down to any size

APPLICATION TYPE:

- Full head bonding only
- *(Must use the NX-Gen Effects/x20/ ProExtreme Application Kit or warranty will be voided)*

MAINTENANCE:

- Minimum 12-14 hair solutions per year

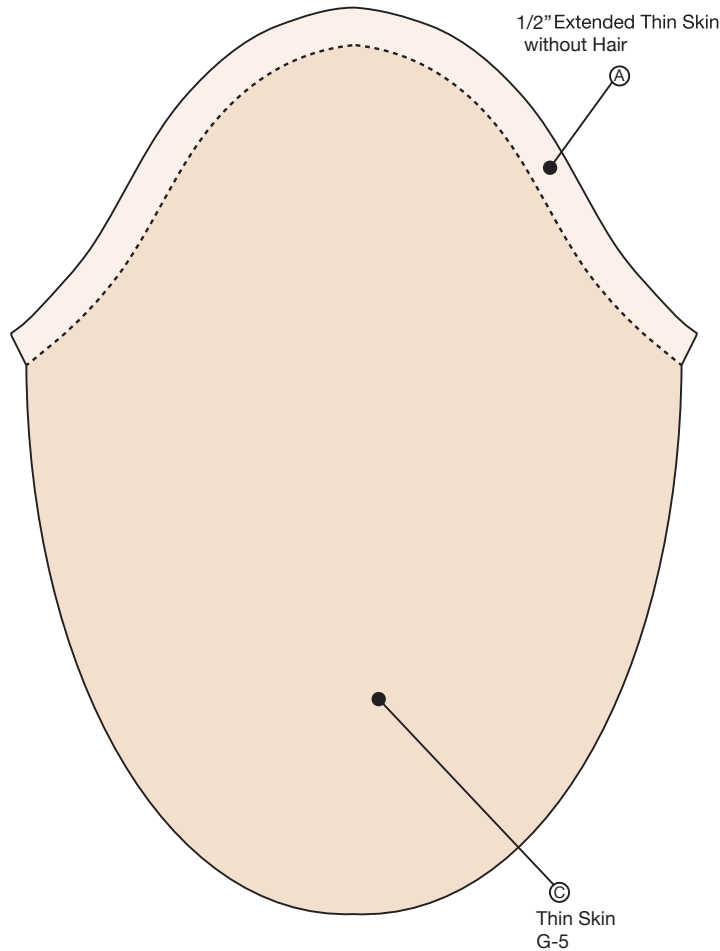

POLYGRAFT II

MSPOLYII

BASE:

- Thin skin base
- 1/2" extended thin skin without hair
- Breathable holes in center

HAIR:

- Type: Human hair, gray is synthetic except 55Y, 65Y, 70Y, 80Y, 85Y, 90Y, 56Y, 57Y, 58Y, 59Y, 60RY where Yak is used (dark is synthetic)
- Length: 4" - 6"
- Wave Pattern: Light wave
- Density: Light to medium throughout, 10% less in front
- Style: Freestyle, available in afro

SIZE:

- 7" x 9 1/2", Can be cut down to any size

APPLICATION TYPE:

- Extended or daily wear
- *(Must use the NX-Gen Effects/x20/ ProExtreme Application Kit or warranty will be voided)*

MAINTENANCE:

- Minimum 4-6 hair solutions per year

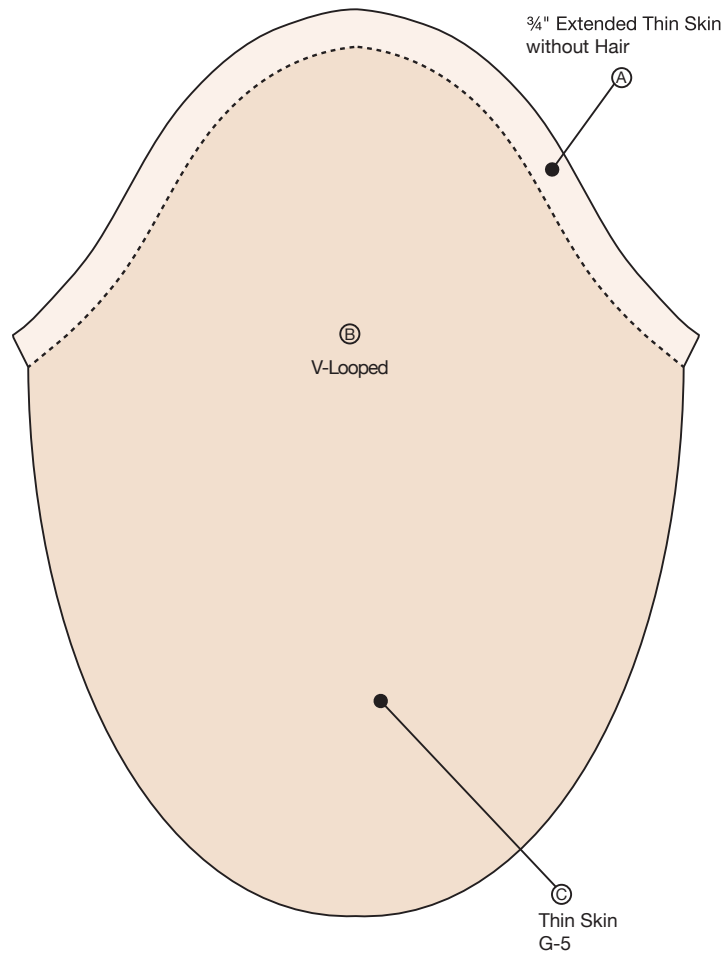

QUANTUM II

MSQ2

BASE:

- Thin skin base
- 3/4" extended thin skin without hair
- V-looped throughout

HAIR:

- Type: Human hair, gray is synthetic except 55Y, 65Y, 70Y, 80Y, 85Y, 90Y, 56Y, 57Y, 58Y, 59Y, 60RY where Yak is used (dark is synthetic)
- Length: 6"
- Wave Pattern: Light wave
- Density: Light to medium throughout
- Style: Freestyle, available in afro

SIZE:

- 8" x 10"
- Can be cut down to any size

APPLICATION TYPE:

- Full head bonding
- *(Must use the NX-Gen Effects/x20/ ProExtreme Application Kit or warranty will be voided)*

MAINTENANCE:

- Minimum 8-10 hair solutions per year

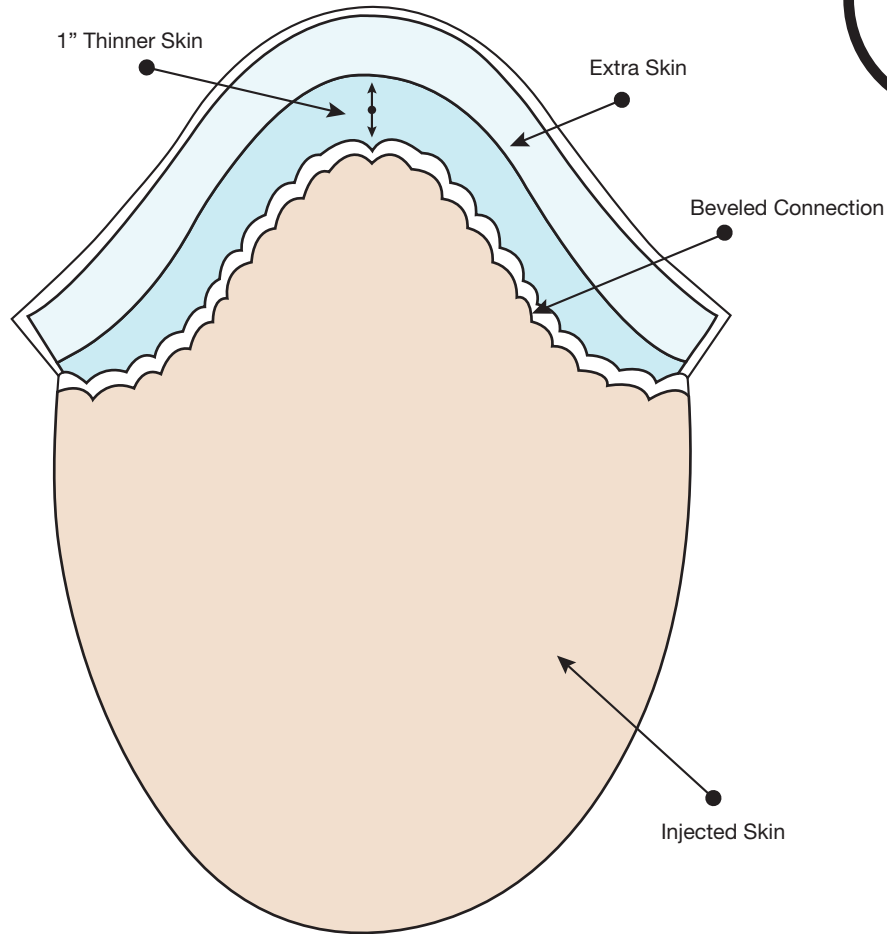
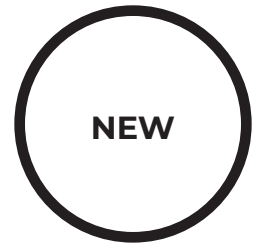

RANDY EPIC

MSRANDYEP

BASE:

- Injected skin base
- 1" thin skin front with extended skin without hair

HAIR:

- Type: Human hair, including gray
- Length: 6"
- Wave Pattern: Light wave
- Density: Light to medium front, plus 5% throughout
- Style: Freestyle

SIZE:

- 8" x 10", Can be cut down to any size

APPLICATION TYPE:

- Extended wear
- *(Must use the NX-Gen Effects/x20/ ProExtreme Application Kit or warranty will be voided)*

MAINTENANCE:

- Minimum 10-14 hair solutions per year

- Available in new colors: #105 #115 #125 #135 #145 #155Y #170Y #190Y #205 #215 #225 #235 #245 #255Y #270Y #290Y #405 #415 #425 #435 #445





COMBINATIONS

MGM

MGM GRAND

MGM ICONIC

POLYGRAFT II FL

QUANTUM VII

QUANTUM VIII

HEADLINER

POLYGRAFT EPIC

POLYGRAFT ICONIC

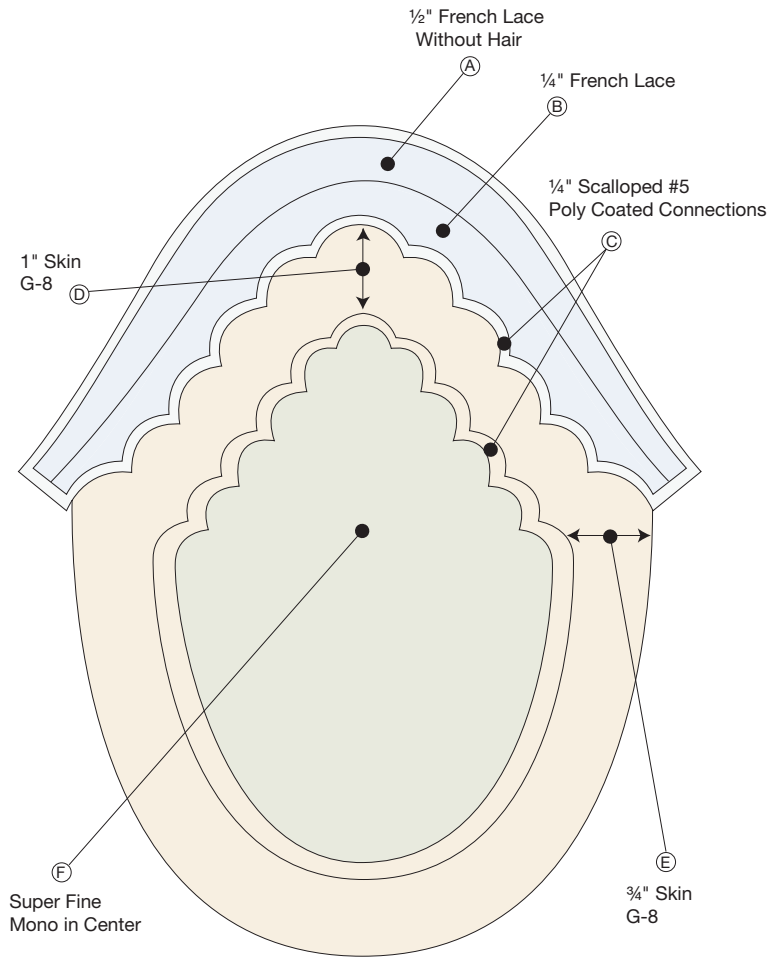

MGM

MSK1157, MSK11568, MSK1179

BASE:

- Extended French lace front
- 1/4" with hair
- 1/2" without hair)
- Scalloped #5 poly coated connections
- Super fine mono center
- 1" in front, 3/4" skin temple to temple

SIZE:

- Available in 3 sizes that can be cut down:
 - Small: 5" x 7"
 - Medium: 6" x 8"
 - Large: 7 1/2" x 9 1/2"

HAIR:

- Type: Human hair, gray is synthetic except 55Y, 65Y, 70Y, 80Y, 85Y, 90Y, 56Y, 57Y, 58Y, 59Y, 60RY where Yak is used (dark is synthetic)
- Length: 4" - 5"
- Wave Pattern: Light wave
- Density: Extra light front, Light throughout
- Style: Freestyle

APPLICATION TYPE:

- Extended or daily wear

MAINTENANCE:

- Minimum 3-4 hair solutions per year

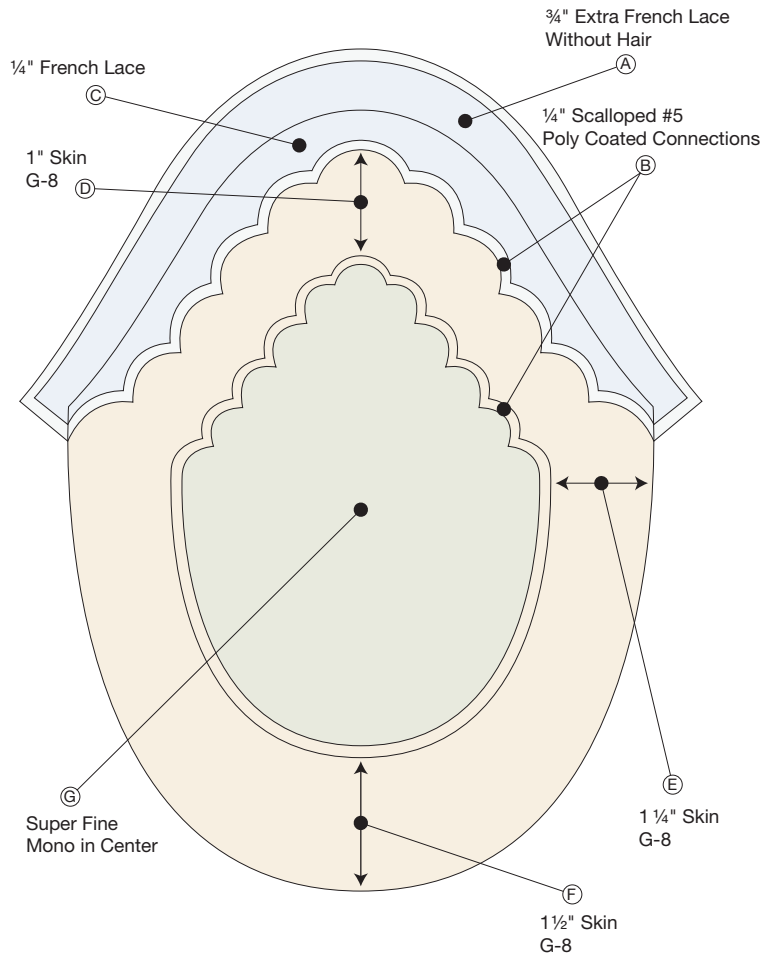

MGM GRAND

MSMGMGR

BASE:

- Extended French lace front (1/4" with hair, 1/2" without hair)
- Scalloped #5 poly coated connections
- Super fine mono center
- Skin around perimeter 1 1/4" on sides blending to 1 1/2" in back
- Colorless knots in front (Colors 2-7, 7ASH, 6R & 8R, up to 20% gray)

HAIR:

- Type: Human hair, gray is synthetic except 55Y, 65Y, 70Y, 80Y, 85Y, 90Y, 56Y, 57Y, 58Y, 59Y, 60RY where Yak is used (dark is synthetic)
- Length: 4" - 6"
- Wave Pattern: Light wave
- Density: Light to medium throughout, light front
- Style: Freestyle

SIZE:

- 7" x 9 1/2"
- Can be cut down to any size

APPLICATION TYPE:

- Perimeter bond or daily wear

MAINTENANCE:

- Minimum 3-4 hair solutions per year

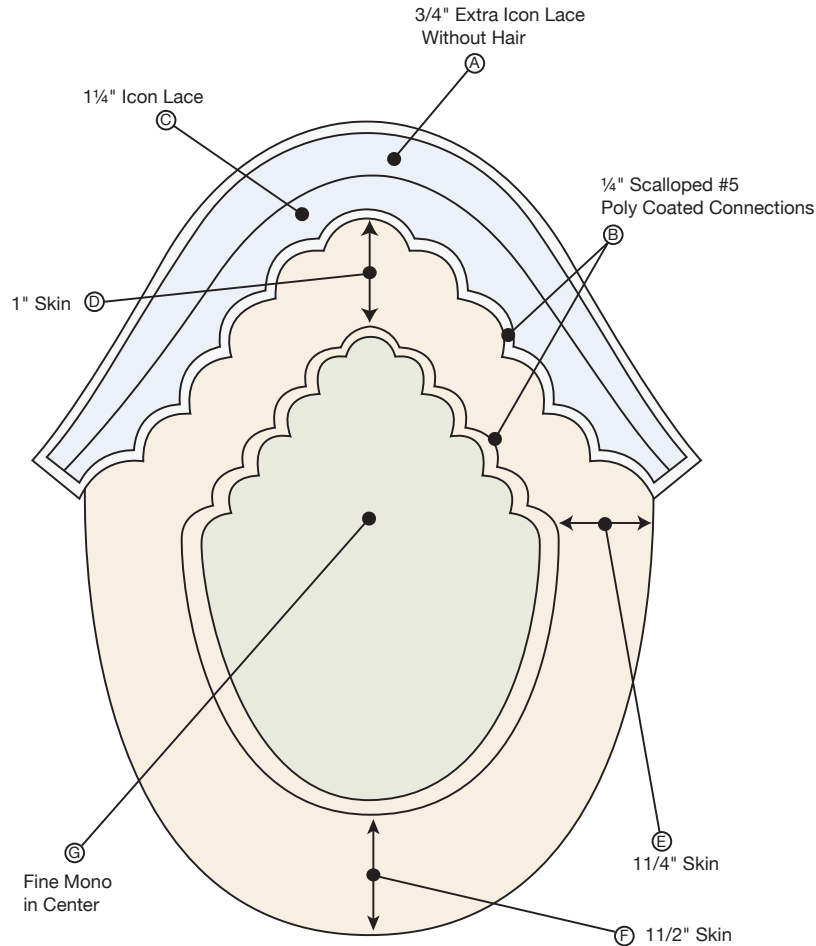
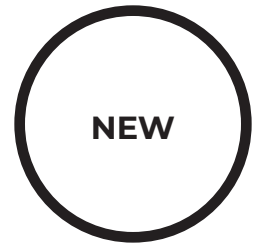

MGM ICONIC

MSMGMGRIC

BASE:

- Extended Icon lace front
- 1 1/4" with hair
- 3/4" without hair
- Scalloped #5 poly coated connections
- Fine mono center
- 1 1/4" skin all around the edge blending to 1 1/2" in back

SIZE:

- 8 1/2" X 11"

APPLICATION TYPE:

- Extended or daily wear

MAINTENANCE:

- Minimum 3-4 hair solutions per year

HAIR:

- Type: Human hair, gray is synthetic except 55Y, 65Y, 70Y, 80Y, 85Y, 90Y, 56Y, 57Y, 58Y, 59Y, 60RY where Yak is used (dark is synthetic)
- Length: 6"
- Wave Pattern: Light wave
- Density: Light to medium front, medium throughout
- Style: Freestyle

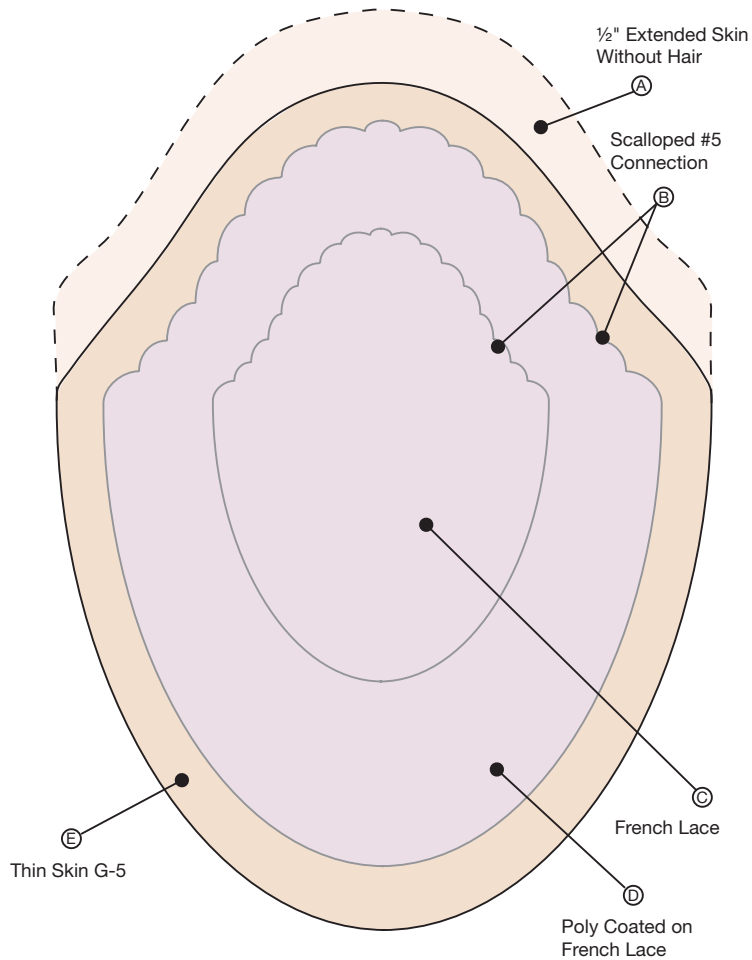

QUANTUM VII

MSQ7LD

BASE:

- French lace base in center
- 1/2" extended skin without hair
- Thin beveled skin edge all around 1 3/4" in front (1/2" thin skin with 1 1/4" poly coating), 1 5/8" on each side (5/8" thin skin with 1" poly coating), 2 1/2" in back (5/8" thin skin with 1 7/8" poly coating)
- V-looped in front

HAIR:

- Type: Human hair, gray is synthetic except 55Y, 65Y, 70Y, 80Y, 85Y, 90Y, 56Y, 57Y, 58Y, 59Y, 60RY where Yak is used (dark is synthetic)
- Length: 4" - 6"
- Wave Pattern: Light wave
- Density: Extra light to light throughout, extra light front
- Style: Freestyle

SIZE:

- 7 1/2" x 9 3/4"
- Can be cut down to any size

APPLICATION TYPE:

- Extended or daily wear

MAINTENANCE:

- Minimum 4-5 hair solutions per year

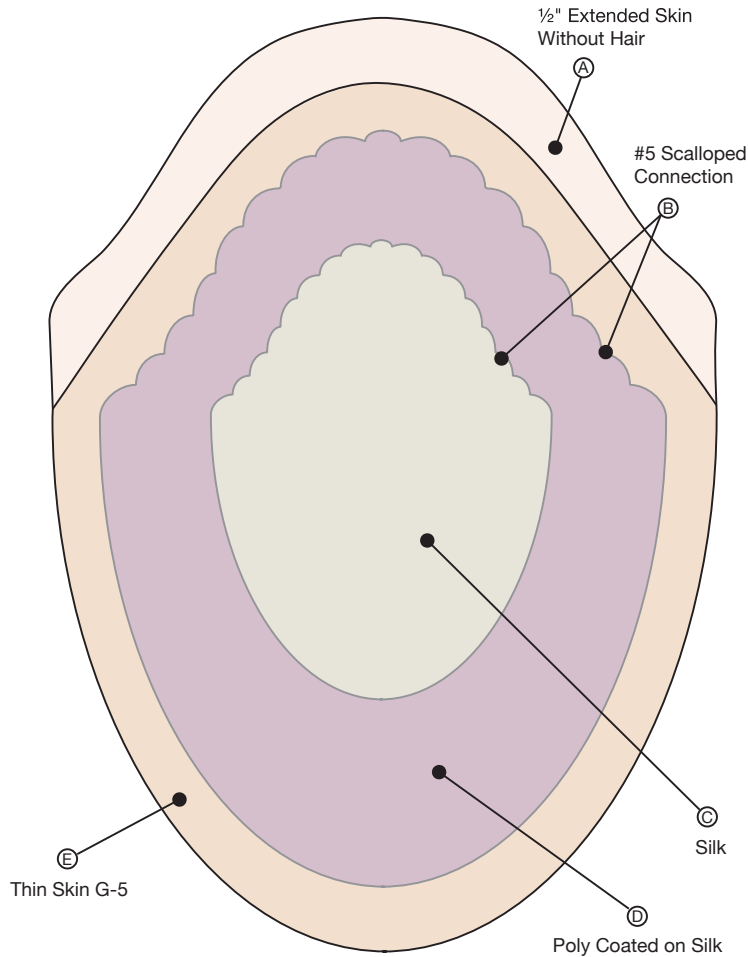

QUANTUM VIII

MSQ8

BASE:

- Silk center
- 1/2" extended skin without hair
- Thin beveled skin edge all around 1 3/4" in front (1/2" thin skin with 1 1/4" poly coating), 1 5/8" on each side (5/8" thin skin with 1" poly coating), 2 1/2" in back (5/8" thin skin with 1 7/8" poly coating)
- 1/2" V-looped in front
- Comfortable and durable as a daily wear unit

HAIR:

- Type: Human hair, gray is synthetic except 55Y, 65Y, 70Y, 80Y, 85Y, 90Y, 56Y, 57Y, 58Y, 59Y, 60RY where Yak is used (dark is synthetic)
- Length: 4" - 6"
- Wave Pattern: Light wave
- Density: Light to medium front, 5% more throughout
- Style: Freestyle

SIZE:

- 7 1/2" x 9 3/4"
- Can be cut down

APPLICATION TYPE:

- Extended or daily wear

MAINTENANCE:

- Minimum 4-5 hair solutions per year

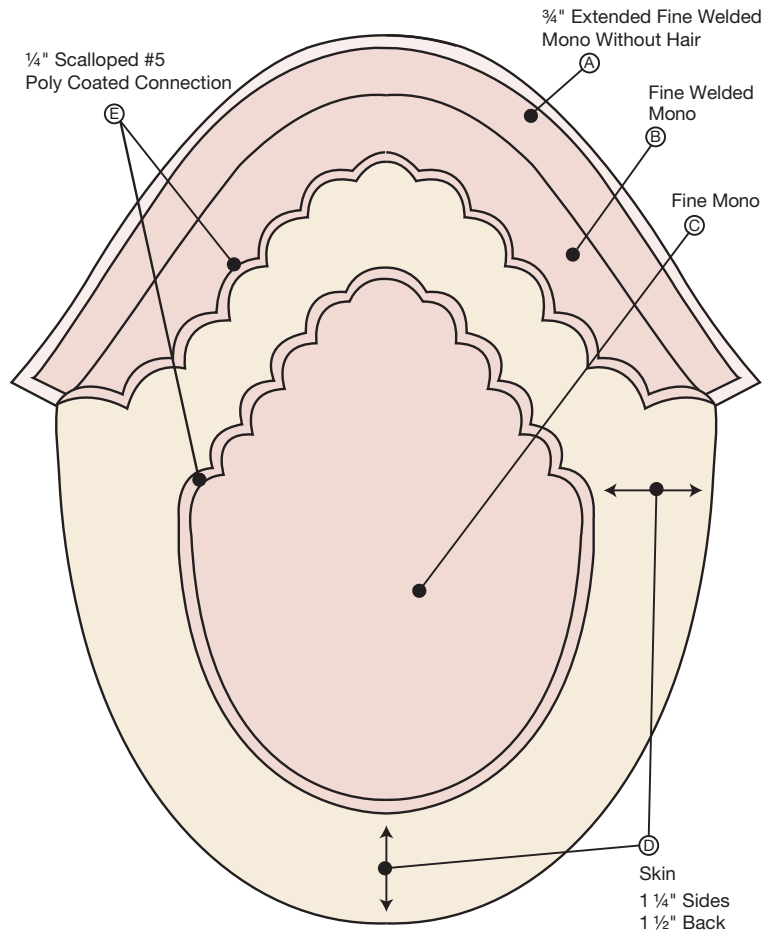

HEADLINER

MSR17

BASE:

- Extended fine welded mono lace front
- Scalloped #5 poly coated connections
- Fine mono center
- 1 1/4" skin all around the edge blending to 2" in back
- Colorless knots in front (Colors 2-7, 7ASH, 6R & 8R, up to 20% gray)

HAIR:

- Type: Human hair, gray is synthetic except 55Y, 65Y, 70Y, 80Y, 85Y, 90Y, 56Y, 57Y, 58Y, 59Y, 60RY where Yak is used (dark is synthetic)
- Length: 4" -5"
- Wave Pattern: Light wave
- Density: Extra light front, Light to medium throughout
- Style: Freestyle

SIZE:

- 7 1/4" x 9 3/4"
- Can be cut down

APPLICATION TYPE:

- Extended or daily wear

MAINTENANCE:

- Minimum 3-4 hair solutions per year

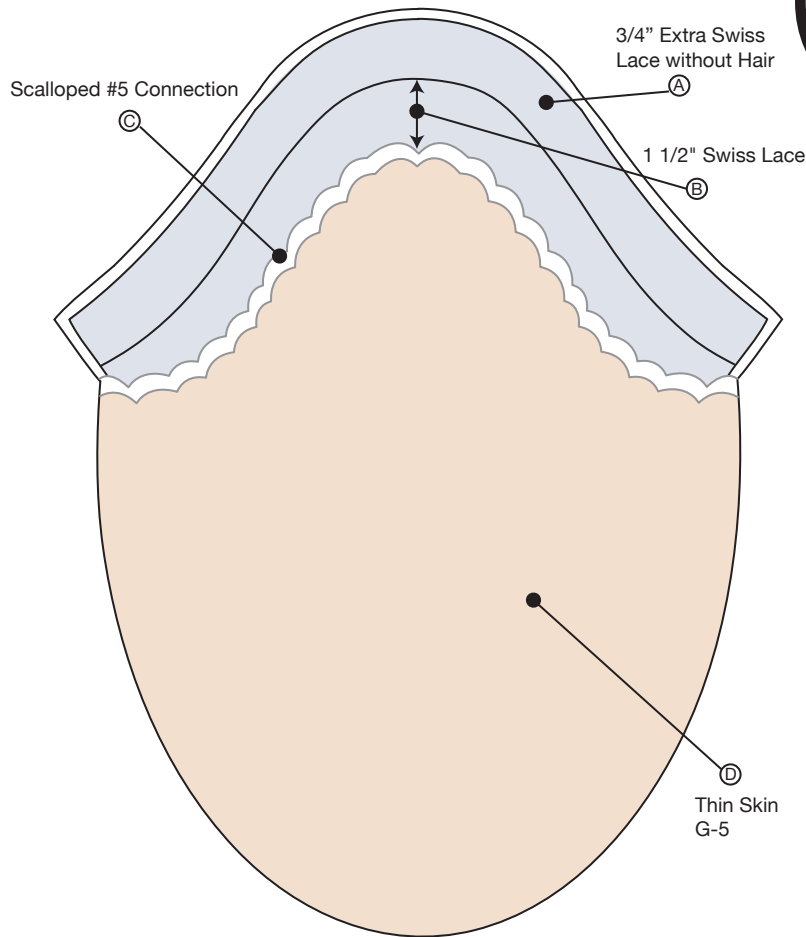

POLYGRAFT EPIC

MSPOLYEP

BASE:

- Thin skin base
- 3/4" extended Swiss lace without hair
- Scalloped connection
- 1 1/2" Swiss lace

HAIR:

- Type: Human hair, gray is synthetic except 55Y, 65Y, 70Y, 80Y, 85Y, 90Y, 56Y, 57Y, 58Y, 59Y, 60RY where Yak is used (dark is synthetic)
- Length: 6"
- Wave Pattern: Light wave
- Density: Light to medium front, medium throughout
- Style: Freestyle

SIZE:

- 8 1/2" x 11", Can be cut down to any size

APPLICATION TYPE:

- Full head bonding only
- *(Must use the NX-Gen Effects/x20/ ProExtreme Application Kit or warranty will be voided)*

MAINTENANCE:

- Minimum 6-12 hair solutions per year

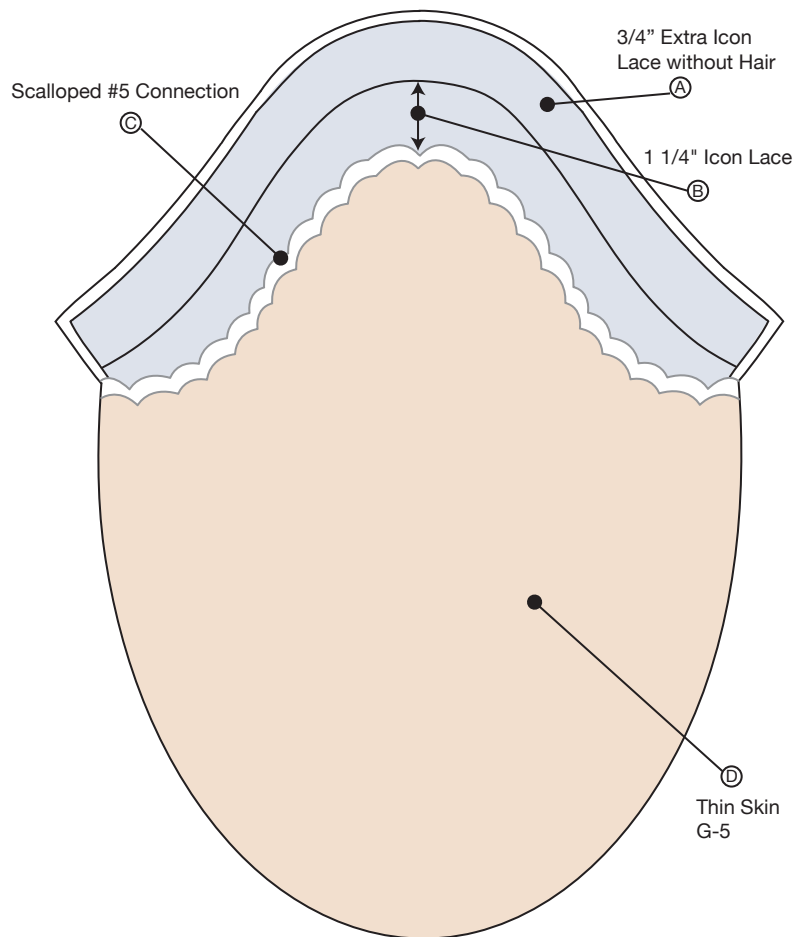
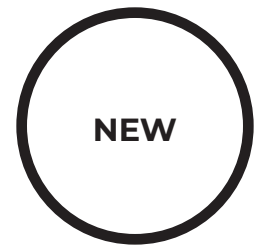

POLYGRAFT ICONIC

MSPOLYIC

BASE:

- Thin skin base
- 3/4" extended Icon lace front without hair
- 1 1/4" Icon lace front with hair
- Scalloped connection

HAIR:

- Type: Human hair, gray is synthetic except 55Y, 65Y, 70Y, 80Y, 85Y, 90Y, 56Y, 57Y, 58Y, 59Y, 60RY where Yak is used (dark is synthetic)
- Length: 6"
- Wave Pattern: Light wave
- Density: Light to medium front, medium throughout
- Style: Freestyle

SIZE:

- 8 1/2" x 11", Can be cut down to any size

APPLICATION TYPE:

- Full head bonding only
- *(Must use the NX-Gen Effects/x20/ ProExtreme Application Kit or warranty will be voided)*

MAINTENANCE:

- Minimum 6-12 hair solutions per year

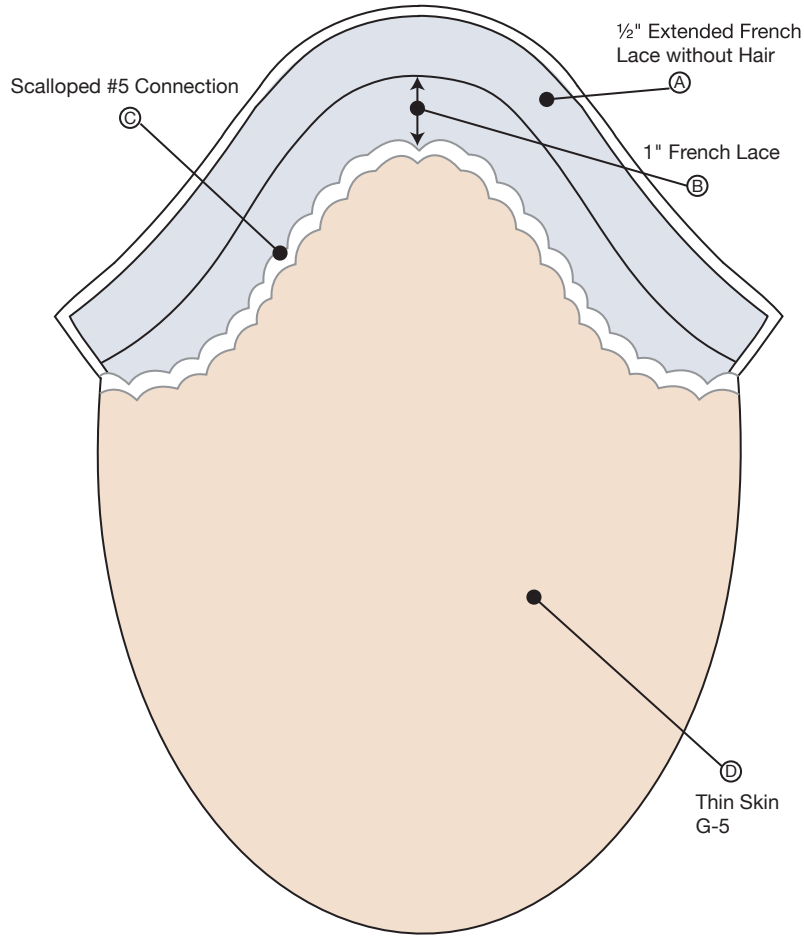

POLYGRAFT II FL

MSFLPOLYII

BASE:

- Thin skin base
- 1" French lace front
- 1/2" extended French lace front without hair
- Scalloped #5 connection
- Breathable holes in center

HAIR:

- Type: Human hair, gray is synthetic except 55Y, 65Y, 70Y, 80Y, 85Y, 90Y, 56Y, 57Y, 58Y, 59Y, 60RY where Yak is used (dark is synthetic)
- Length: 4" - 6"
- Wave Pattern: Light wave
- Density: Light to medium throughout
- Style: Freestyle

SIZE:

- 7 3/4" x 10 1/4", Can be cut down to any size

APPLICATION TYPE:

- Extended or daily wear

MAINTENANCE:

- Minimum 4-6 hair solutions per year





FULL CAPS

ALEX

ALEX ICONIC

ALEX EPIC

XTS FULL CAP

POLYGRAFT II FULL CAP

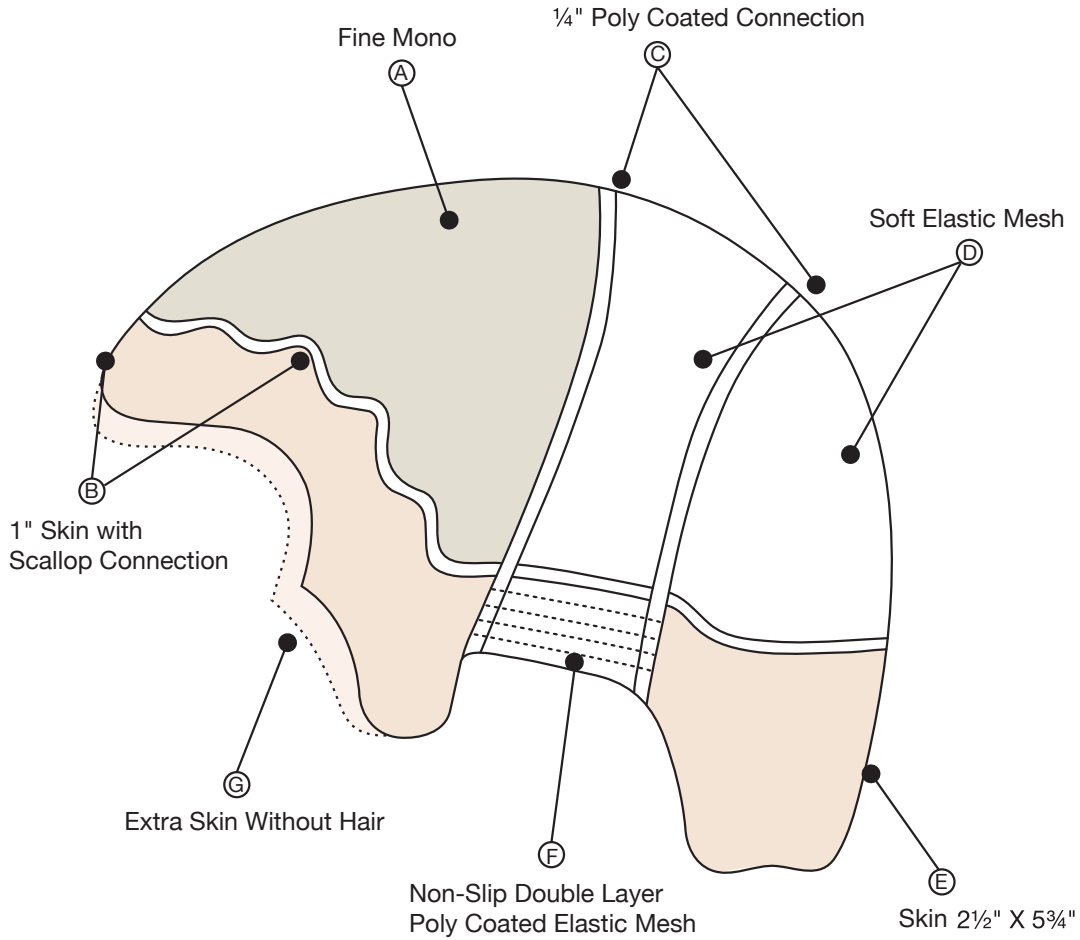

ALEX

MSALEX

BASE:

- New, non-slip Flex-Form technology adjust automatically for comfortable, custom fit
- 1" skin front with scalloped connection
- Extended skin front without hair
- Fine mono top
- Soft elastic mesh around back with 1/4" poly coated connection lines
- 2 1/2" skin in nape

SIZE:

- Circumference: 22"
- Temple to temple: 14 1/4"
- Ear to ear: 12 1/2"

APPLICATION TYPE:

- Extended or daily wear

MAINTENANCE:

- Minimum 3-4 hair solutions per year

HAIR:

- Type: Human hair, gray is synthetic except 55Y, 65Y, 70Y, 80Y, 85Y, 90Y, 56Y, 57Y, 58Y, 59Y, 60RY where Yak is used (dark is synthetic)
- Length: 5"
- Wave Pattern: Light wave
- Density: Light to medium throughout
- Style: Freestyle

NEW

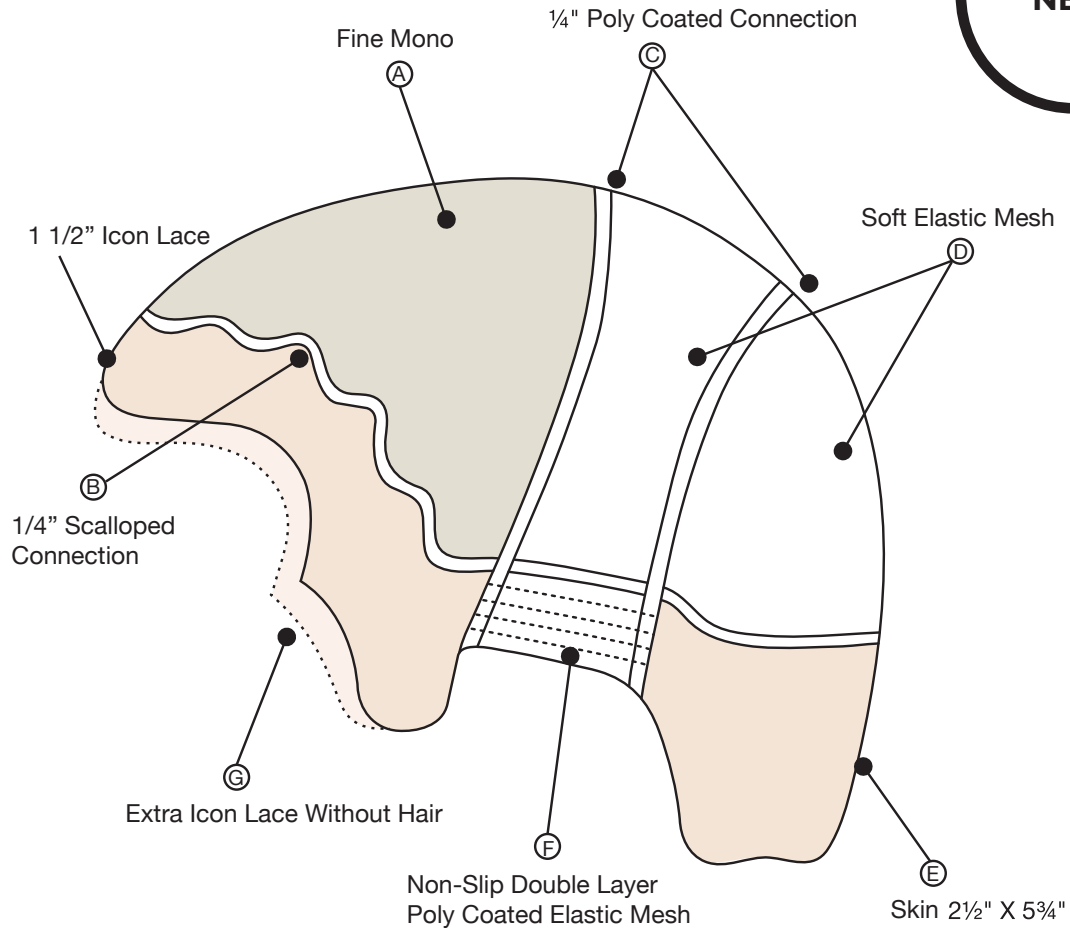

ALEX ICONIC

MSALEXIC

BASE:

- New, non-slip Flex-Form technology adjust automatically for comfortable, custom fit
- 1 1/2" Icon lace front with scalloped connection
- Extended Icon lace front without hair
- Fine mono top
- Soft elastic mesh around back with 1/4" poly coated connection lines
- 2 1/2" skin in nape

SIZE:

- Circumference: 22"
- Temple to temple: 14 1/4"
- Ear to ear: 12 1/2"

APPLICATION TYPE:

- Extended or daily wear

MAINTENANCE:

- Minimum 3-4 hair solutions per year

HAIR:

- Type: Human hair, gray is synthetic except 55Y, 65Y, 70Y, 80Y, 85Y, 90Y, 56Y, 57Y, 58Y, 59Y, 60RY where Yak is used (dark is synthetic)
- Length: 6"
- Wave Pattern: Light wave
- Density: Light to medium front, medium throughout
- Style: Freestyle

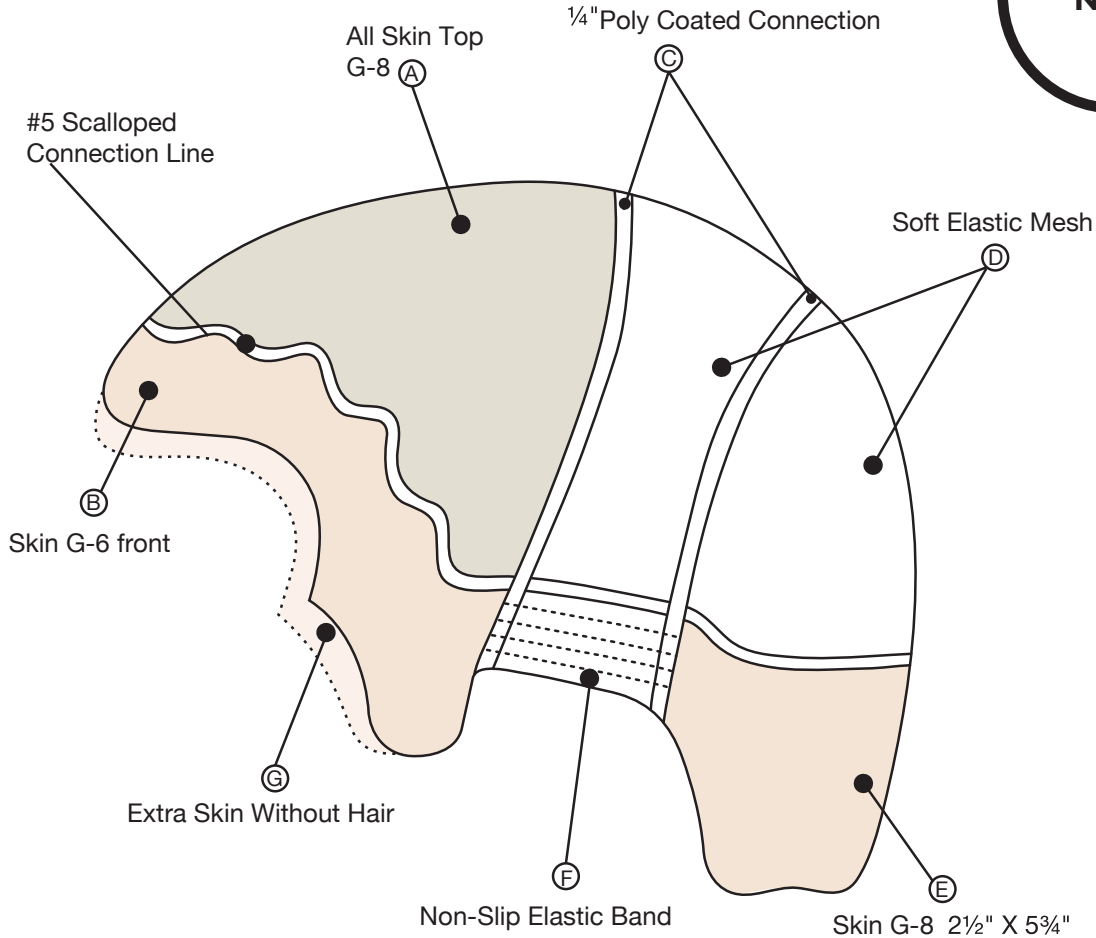

ALEX EPIC

MSALEXEP

BASE:

- New, non-slip Flex-Form technology adjust automatically for comfortable, custom fit
- Skin front with bereled connection
- Extended skin front without hair
- All skin top
- Soft elastic mesh around back with 1/4" poly coated connection lines
- 2 1/2" skin in nape

SIZE:

- Circumference: 22"
- Temple to temple: 14 1/4"
- Ear to ear: 12 1/2"

APPLICATION TYPE:

- Extended or daily wear

MAINTENANCE:

- Minimum 3-4 hair solutions per year

HAIR:

- Type: Human hair, gray is synthetic except 55Y, 65Y, 70Y, 80Y, 85Y, 90Y, 56Y, 57Y, 58Y, 59Y, 60RY where Yak is used (dark is synthetic)
- Length: 6"
- Wave Pattern: Light wave
- Density: Light to medium front, medium throughout
- Style: Freestyle

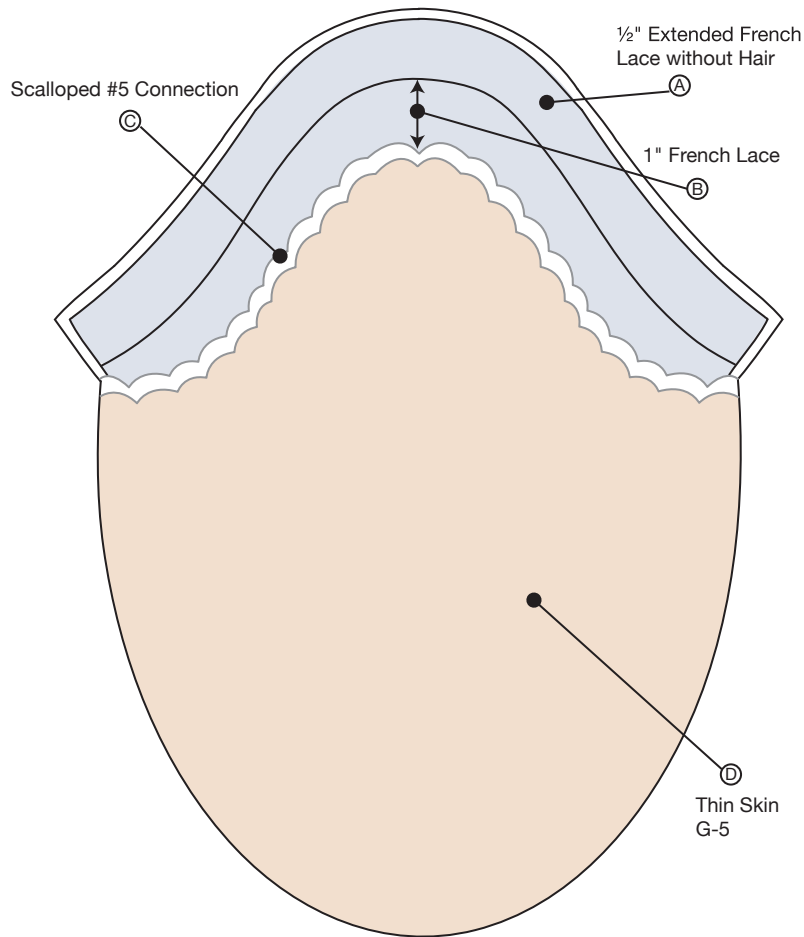

POLYGRAFT FL II

MSFLPOLYII

BASE:

- Thin skin base
- 1" French lace front
- 1/2" extended French lace front without hair
- Scalloped #5 connection
- Breathable holes in center

HAIR:

- Type: Human hair, gray is synthetic except 55Y, 65Y, 70Y, 80Y, 85Y, 90Y, 56Y, 57Y, 58Y, 59Y, 60RY where Yak is used (dark is synthetic)
- Length: 4" - 6"
- Wave Pattern: Light wave
- Density: Light to medium throughout
- Style: Freestyle

SIZE:

- 7 3/4" x 10 1/4", Can be cut down to any size

APPLICATION TYPE:

- Extended or daily wear

MAINTENANCE:

- Minimum 4-6 hair solutions per year

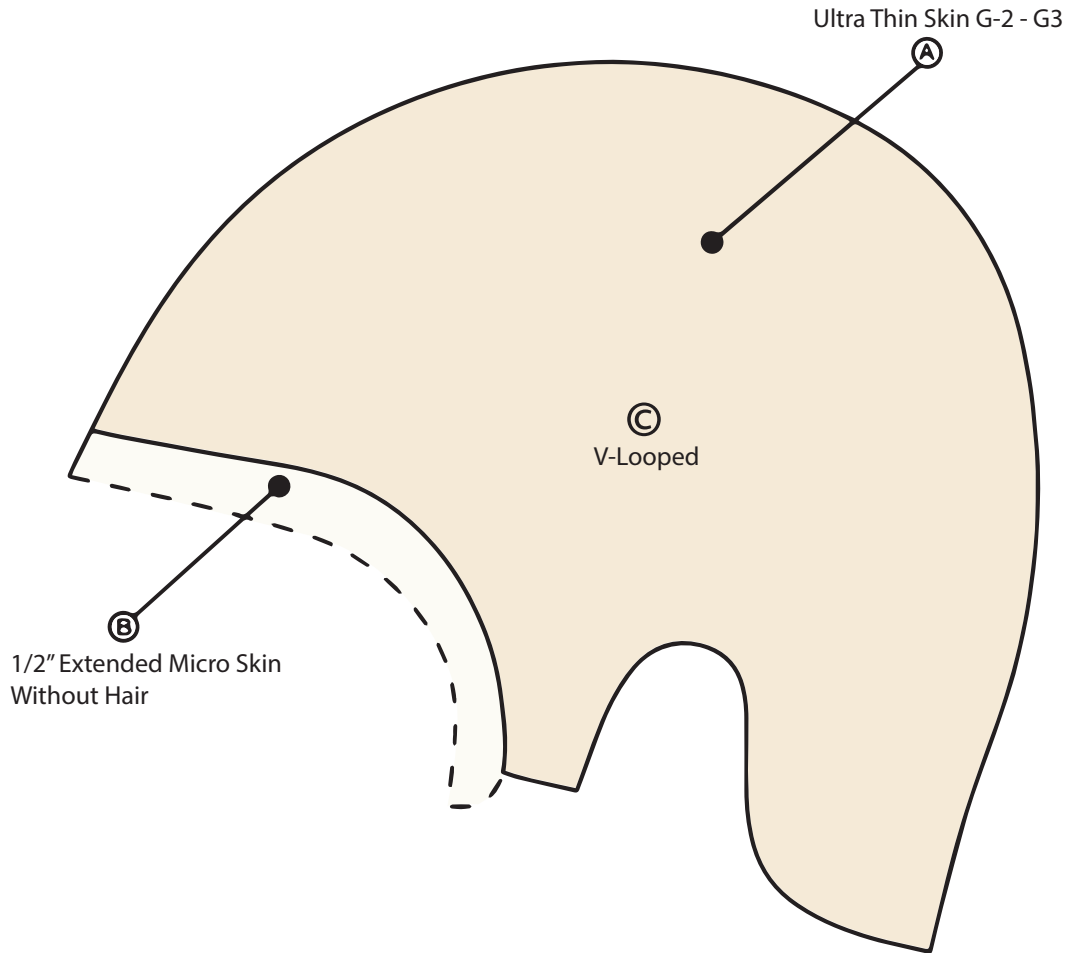

XTS FULL CAP

MSXTSFC

BASE:

- Ultra-thin skin base, extended skin without hair temple to temple over the head
- V-looped throughout
- No cleanup, no repairs, & no oxidation as a "throw-away" unit

HAIR:

- Type: Human hair, gray is synthetic except 55Y, 65Y, 70Y, 80Y, 85Y, 90Y, 56Y, 57Y, 58Y, 59Y, 60RY where Yak is used (dark is synthetic)
- Length: 6"
- Wave Pattern: Light wave
- Density: Light to medium throughout, 10% less for rest
- Style: Freestyle

SIZE:

- Circumference: 21 1/4"
- Temple to Temple: 15"
- Ear to Ear: 11"

APPLICATION TYPE:

- Full head bonding only
- *(Must use the NX-Gen Effects/x20/ ProExtreme Application Kit or warranty will be voided)*

MAINTENANCE:

- Minimum 12-18 hair solutions per year

ELITE.M

Class

WWW.NEWIMAGELABS.COM

1501 Northpoint Parkway, Suite 100, West Palm Beach, FL 33407
Toll Free 1-800-359-4247 | **Local** 1-561-697-9494 | **Fax** 1-561-697-4944

6-6305 Northam Drive, Mississauga, Ontario, Canada L4V1W9
Toll Free 1-855-367-6367 | **Local** 905-203-1986